



COMPRAR  
TOLDOS.COM



cofres

**K-Set  25**

## Características y aplicaciones



El nuevo K-Set Q25 se une a la familia de cofres de líneas rectas que redundan en la evolución y la estética adaptadas íntegramente a la arquitectura actual, aunando versatilidad con las construcciones existentes.

El cofre se suministra en un kit de dos perfiles. Permite dimensiones máximas de 5 metros de línea por 2 metros de salida.

Se puede montar a pared o techo, con un rango de inclinación de 5° a 65°, la regulación es sencilla y efectiva, clave a la hora de facilitar su montaje con un resultado limpio y perfecto.

Accionamiento manual o motorizado, posibilidad de iluminación LED en el perfil de la lona.

Montaje y desmontaje frontal de la tapa lona motor.

Fabricado y certificado según la norma UNE EN 13561:2015/AC.

## Characteristics and applications



The new K-Set Q25 joins the family of boxes with straight lines that result in evolution and aesthetics fully adapted to current architecture, combining versatility with existing constructions.

The box is supplied in a kit of two profiles. It allows maximum dimensions of 5 meters of line by 2 meters of projection.

It can be mounted on a wall or ceiling, with an inclination range of 5° to 65°, the regulation is simple and effective, key when it comes to facilitating its assembly with a clean and perfect result.

Manual or motorized operation, possibility of LED lighting on the canvas profile.

Front assembly and disassembly of the motor canvas cap.

Manufactured and certified according to the UNE EN 13561:2015/AC standard.

## Caractéristiques et les usages



Le nouveau K-Set Q25 rejoint la famille des coffres aux lignes droites qui se traduisent par une évolution et une esthétique entièrement adaptées à l'architecture actuelle, alliant polyvalence avec les constructions existantes.

Le coffre est fourni dans un kit de deux profils. Il permet des dimensions maximales de 5 mètres de ligne par 2 mètres de sortie.

Il peut être monté au mur ou au plafond, avec une plage d'inclinaison de 5° à 65°, le réglage est simple et efficace, essentiel pour faciliter son montage avec un résultat propre et parfait.

Fonctionnement manuel ou motorisé, possibilité d'éclairage LED sur le profilé en toile.

Montage et démontage avant de la couvercle de toile moteur.

Fabriqué et certifié selon la norme UNE EN 13561:2015/AC.

## Características e aplicações



A nova K-Set Q25 junta-se à família dos cofres com linhas retas que resultam numa evolução e estética totalmente adaptada à arquitetura atual, aliando versatilidade às construções existentes.

O cofre é fornecida num kit de dois perfis. Permite dimensões máximas de 5 metros de linha por 2 metros de saída.

Pode ser montado na parede ou no teto, com faixa de inclinação de 5° a 65°, a regulagem é simples e eficaz, fundamental para facilitar sua montagem com um resultado limpo e perfeito.

Funcionamento manual ou motorizado, possibilidade de iluminação LED no perfil da lona.

Montagem frontal e desmontagem da tampa lona do motor.

Fabricado e certificado de acordo com a norma UNE EN 13561:2015/AC.





# K-Set Q25

Despiece - K-Set Q25 parts - Pièces de K-Set Q25 - Lista de peças K-Set Q25

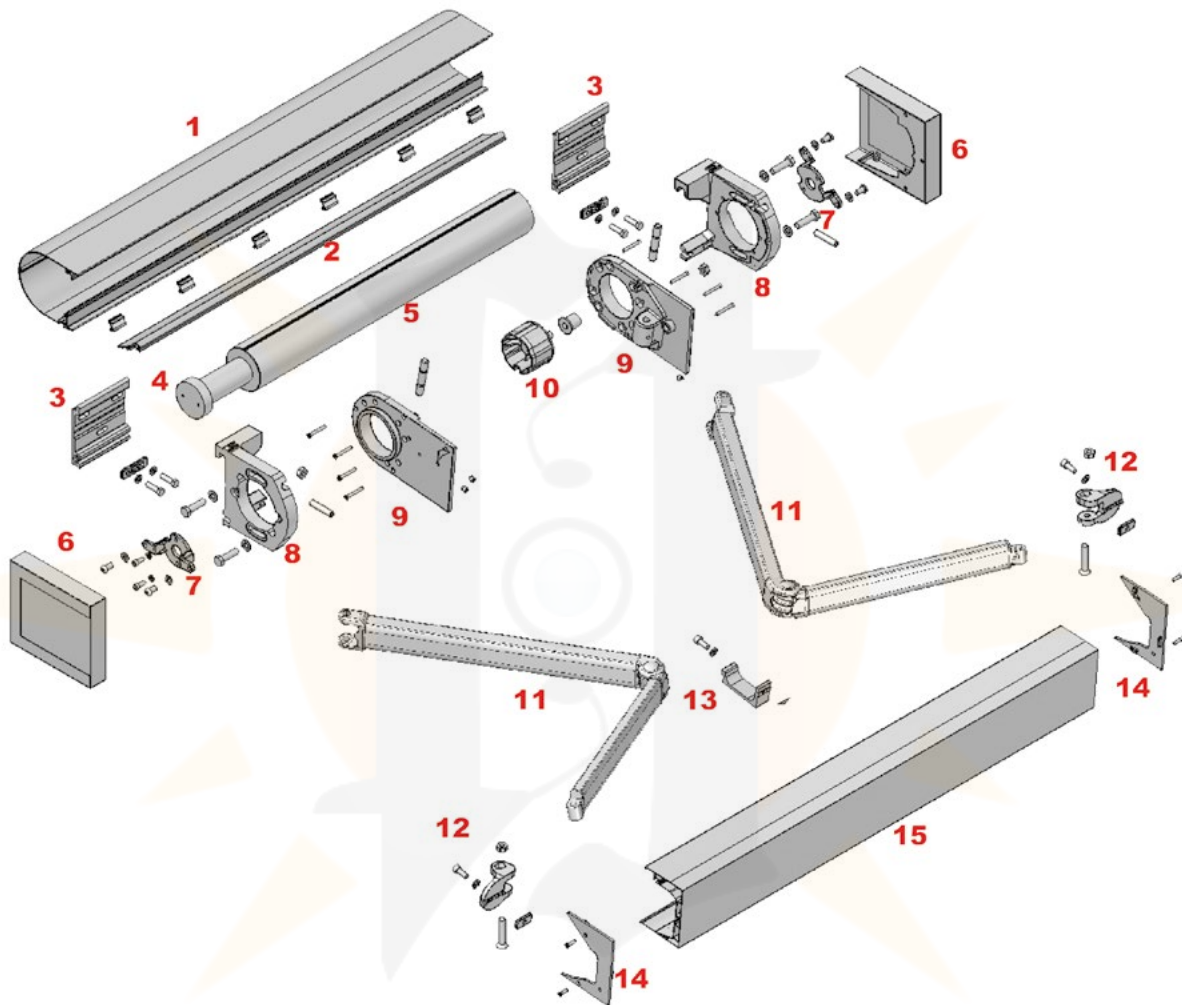

- 1: Perfil de lona
- 2: Banda antirroce
- 3: Placa pared
- 4: Motor
- 5: Tubo de enroll
- 6: Tapa lona
- 7: Acople
- 8: Soporte cuelgue
- 9: Soporte brazos
- 10: Casquillo punta con eje
- 11: Brazos Compac
- 12: Terminal
- 13: Tope cierre
- 14: Tapas perfil de carga
- 15: Perfil de carga



- 1: Canvas profile
- 2: Anti-friction band
- 3: Wall plate
- 4: Motor
- 5: Roller tube
- 6: Canvas cap
- 7: Coupling
- 8: Hanging support
- 9: Arms support
- 10: End gudgeon with shaft
- 11: Compac arms
- 12: Terminal
- 13: Closing stop
- 14: Load profile plugs
- 15: Load profile



- 1: Profilé de toile
- 2: Bande anti-frottement
- 3: Platine murale
- 4: Moteur
- 5: Tube d'enroulement
- 6: Couverde de toile
- 7: Raccord
- 8: Support fixation
- 9: Support de bras
- 10: Douille de pointe avec axe
- 11: Bras Compac
- 12: Griffes
- 13: Butoir de fermeture
- 14: Jous barre de charge
- 15: Profilé de charge



- 1: Perfil de lona
- 2: Banda antifricção
- 3: Placa parede
- 4: Motor
- 5: Tubo de enrolamento
- 6: Tampa lona
- 7: Acoplamento
- 8: Suporte de pendurar
- 9: Suporte braços
- 10: Casquilho ponta com eixo
- 11: Braços Compac
- 12: Terminal
- 13: Topo fecho
- 14: Tampas perfil de carga
- 15: Perfil de carga

Kit Tapa Máquina (máquina no incluida) - Ref. 441500\_\_

Kit Tapa Motor - Ref. 441600\_\_

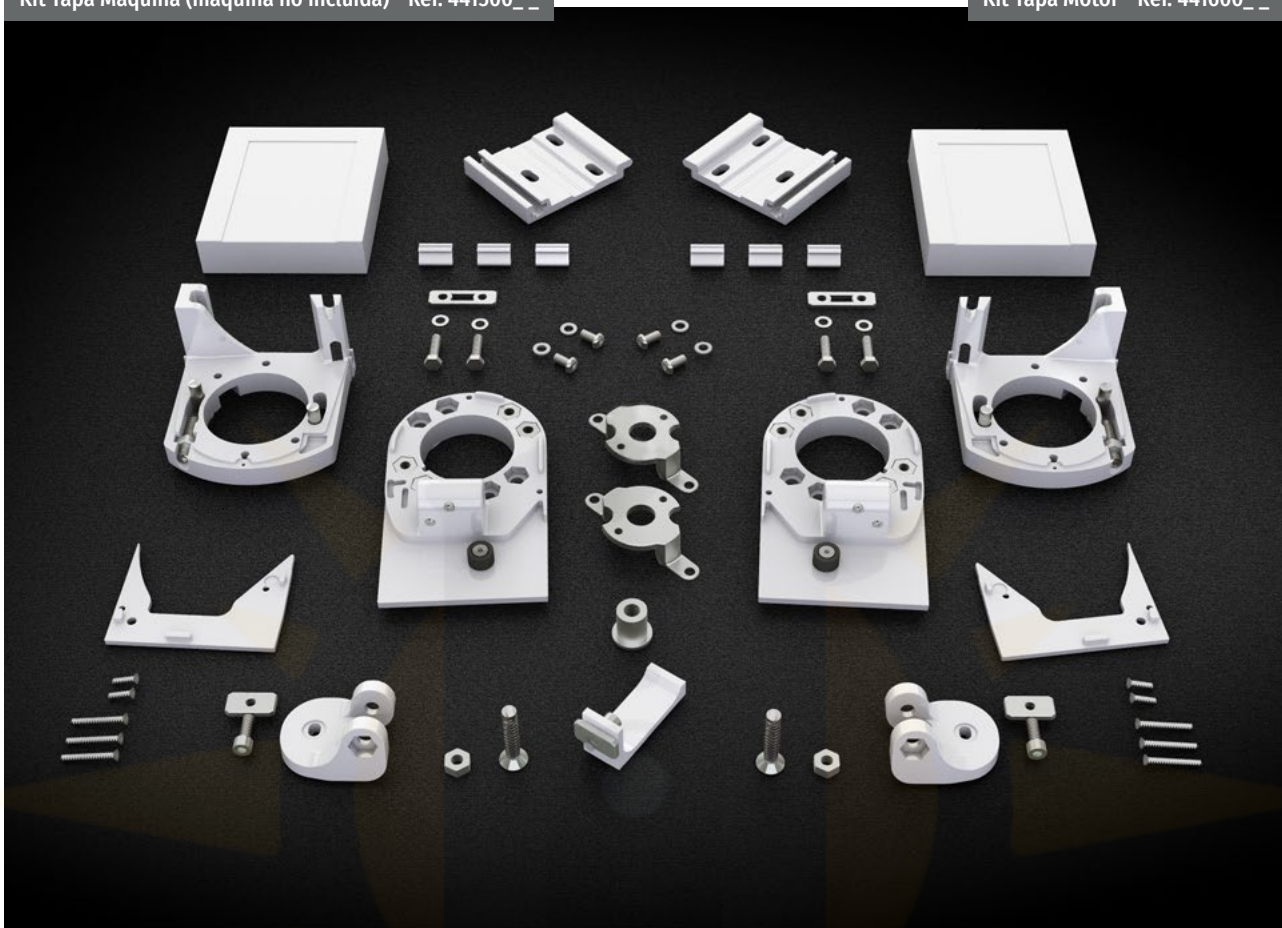

Kit de Accesorios K-Set Q25  
 K-Set Q25 Accessory Kit  
 Kit d'accessoires K-Set Q25  
 Kit de Acessórios K-Set Q25

Ref. 41040000



Banda antiroce  
 Anti-friction strip  
 Bande anti-frottement  
 Banda antifricção

Ref. 4410\_\_\_\_\_



Kit 2 Perfiles Cofre K-Set Q25 / Cofre K-Set Q25 2 Profile Kit  
 Kit 2 Profils Cofre K-Set Q25 / Kit 2 Perfis Cofre K-Set Q25

Ref. Difusor-cofres



Difusor para iluminación led  
 Led illumination diffuser  
 Diffuseur / Difusor para iluminação led

Ref. 3125\_\_\_\_\_



Juego Brazo Compac  
 Compac Arm Kit

Jeu Bras Compac  
 Jogo Braço Compac

INCLINACIÓN MÍN. PARED 5° INCLINACIÓN MÁX. PARED 65°

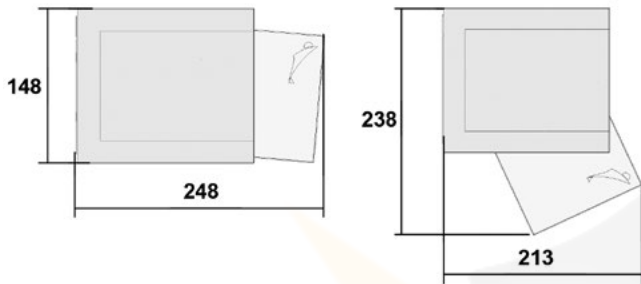

INCLINACIÓN MÍN. TECHO 5° INCLINACIÓN MÁX. TECHO 65°

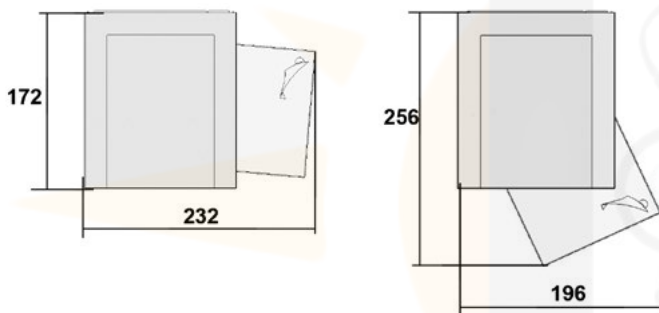

DIMENSIONES PLACA PARED

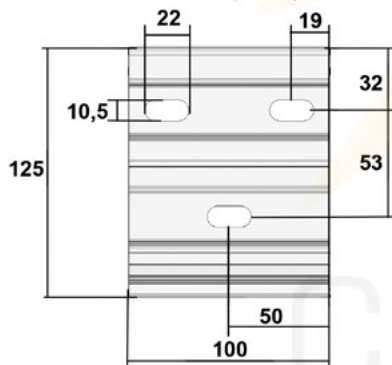

LINEAS MÍNIMAS CON BRAZO COMPAC (tapas incluidas) MINIMUM LINES WITH COMPAC ARM (caps included) MINIMAL DE LARGEURS AVEC BRAS COMPAC (tapas dont) LINHAS MÍNIMAS COM BRAÇO COMPAC (tampas incluídas)		
SALIDA (m) PROJECTION (m) AVANÇEE (m) PROJEÇÃO (m)	MANUAL MANUEL MANUEL	MOTOR MOTOR MOTEUR MOTOR
1,25	1,670	1,620
1,50	1,920	1,870
1,75	2,170	2,120
2,00	2,420	2,370
2,25	2,690	2,640
2,50	2,920	2,870

MEDIDAS DE LOS TUBOS (no admite holguras) / ROLLER TUBE MEASUREMENTS (no clearance) MESURES DU TUBE D'ENROULEMENT (il ne doit pas y avoir de jeu entre les pièces) / MEDIDAS DOS TUBOS (não admite folgas)			
	MANUAL MANUEL MANUEL	MOTOR SIN SOPORTE MOTOR WITHOUT SUPPORT MOTEUR SANS SUPPORT MOTOR SEM SUPORTE	MOTOR CON SOPORTE MOTOR WITH SUPPORT MOTEUR AVEC SUPPORT MOTOR COM SUPORTE
TUBO DE ENROLLE (TE) ROLLING TUBE TUBE ROULÉ TUBO DE ENROLAMENTO	LT-170 mm	LT-125mm	LT-133 mm
PERFIL LONA (PL) CANVAS PROFILE PROFIL DE LA TOILE PERFIL LONA	LT-155 mm	LT-105 mm	LT-105 mm
PERFIL CARGA (PC) LOAD PROFILE PROFIL CHARGER PERFIL CARGA	LT-155 mm	LT-105 mm	LT-105 mm

(\*) Para motores SOMFY deberá utilizarse el soporte especial ref.9707838

SALIDA (m) PROJECTION AVANÇEE / PROJEÇÃO	LÍNEA - LINE - LARGEUR - LINHA						
	2	2,5	3	3,5	4	4,5	5
1,25							
1,5							
1,75	I. M.						
2	I. M.						
2,25	I. M.	I. M.					I. M.
2,5	I. M.	I. M.				I. M.	I. M.

**RESISTENCIA AL VIENTO / Clasificación de producto**  
**WIND RESISTANCE / Classification of product**  
**RESISTANCE AU VENT / Classification du produit**  
**RESISTÊNCIA AO VENTO / Classificação de produto**

**CLASE 2 38 Km/h.**

Ensayo de resistencia al viento, realizado conforme a la norma EN 13561:2015/AC  
Wind resistance test conducted according to standard EN 13561:2015/AC  
Test de résistance au vent, réalisé conformément à la norme EN 13561:2015/AC  
Ensaio de resistência ao vento, realizado de acordo com a norma EN 13561:2015/AC

I.M. = Imposibilidad de montaje / impossibility of assembly  
impossibilité de montage / impossibilidade de montagem

PAR MÍNIMO DEL MOTOR SEGÚN TUBO DE ENROLLE, LÍNEA Y SALIDA / MINIMUM TORQUE OF MOTOR ACCORDING TO ROLLER TUBE, WIDTH AND PROJECTION COUPLE MINIMUM DU MOTEUR SUIVANT TUBE D'ENROULEMENT, LIGNE ET AVANÇEE / PAR MÍNIMO DO MOTOR SEGUNDO TUBO DE ENROLAMENTO, LINHA E PROJEÇÃO							
Ejes de enrollamiento diámetro 70 mm / Rolling axis diameter 70 mm / Diamètre axe d'enroulement 70 mm / Eixos de enrolamento diâmetro 70 mm.							
Ø70	SALIDA (m) / PROJECTION AVANÇEE / PROJEÇÃO	1,25	1,5	1,75	2	2,25	2,50
	PAR MÍNIMO / LINE UP TO 6 m. 2 ARMS LARGEUR JUSQU'À 6 m. 2 BRAS / LINHA ATÉ 6 m. 2 BRAÇOS	40	40	40	40	40	40



COMPRAR  
TOLDOS.COM

**La gama más alta de Siplan**

Siplan's premium range  
Le plus haut de gamme de Siplan  
A gama mais elevada da Siplan