

# Dúplex



**2EN1**

## Características y aplicaciones



Sistema de toldo dual, muy útil en terrazas y lugares donde se requieran pocos puntos de apoyo.

El cabezal del Sistema Dúplex nos permite desplegar dos toldos con brazo articulado, enrollando ambas lonas sobre el mismo tubo, con una sola máquina, consiguiendo así un mecanismo eficaz y optimizado.

Línea máxima 5 m. Salida máxima 2,75 m. a cada lado.

### **IMPORTANTE:**

**La estructura de este sistema doble debe ser tubo de hierro de 80x40x2 mm.**

## Characteristics and applications



Dual awning system, highly useful in terraces and places that require few support points.

The Duplex System header board means that two awnings can be opened out with an articulated arm, rolling both canvases on the same tube with one single device, achieving an effective and optimised mechanism.

Maximum line 5 m. Maximum projection 2,75 m. to each side.

### **IMPORTANT:**

**The structure of this double system should be an iron tube measuring 80x40x2 mm.**

## Caractéristiques et les usages



Système de double store, très utile sur terrasses et lieux où peu de points d'appui sont requis.

La tête du Système Duplex nous permet de déployer deux stores avec bras articulé, en enrollant deux toiles sur le même tube, avec une seule machine, en obtenant ainsi un mécanisme efficace et optimisé.

Ligne maximale 5 m. Avancée maximale 2,75 m. de chaque côté.

### **IMPORTANT:**

**La structure de ce système double doit être un tube en fer de 80x40x2 mm.**

## Eigenschaften und Anwendungen



Freistehende doppelseitige Gelenkarmmarkise, sehr geeignet für Terrassen.

Mit dem System Duplex können wir zwei Markisen mit Gelenkarm aufspannen und beide Planen auf dem gleichen Rohr mit nur einer Maschine mittels einem effizienten, optimierten Mechanismus aufwickeln.

Max. Linie 5m, max. Ausladung 2,75 m.

### **WICHTIG:**

**Die Struktur dieses doppelten Systems benötigt ein Stahltragrohr von 80x40x2 mm.**



# Dúplex

Despiece - Duplex parts - Pièces de Duplex - Komponenten der Duplex

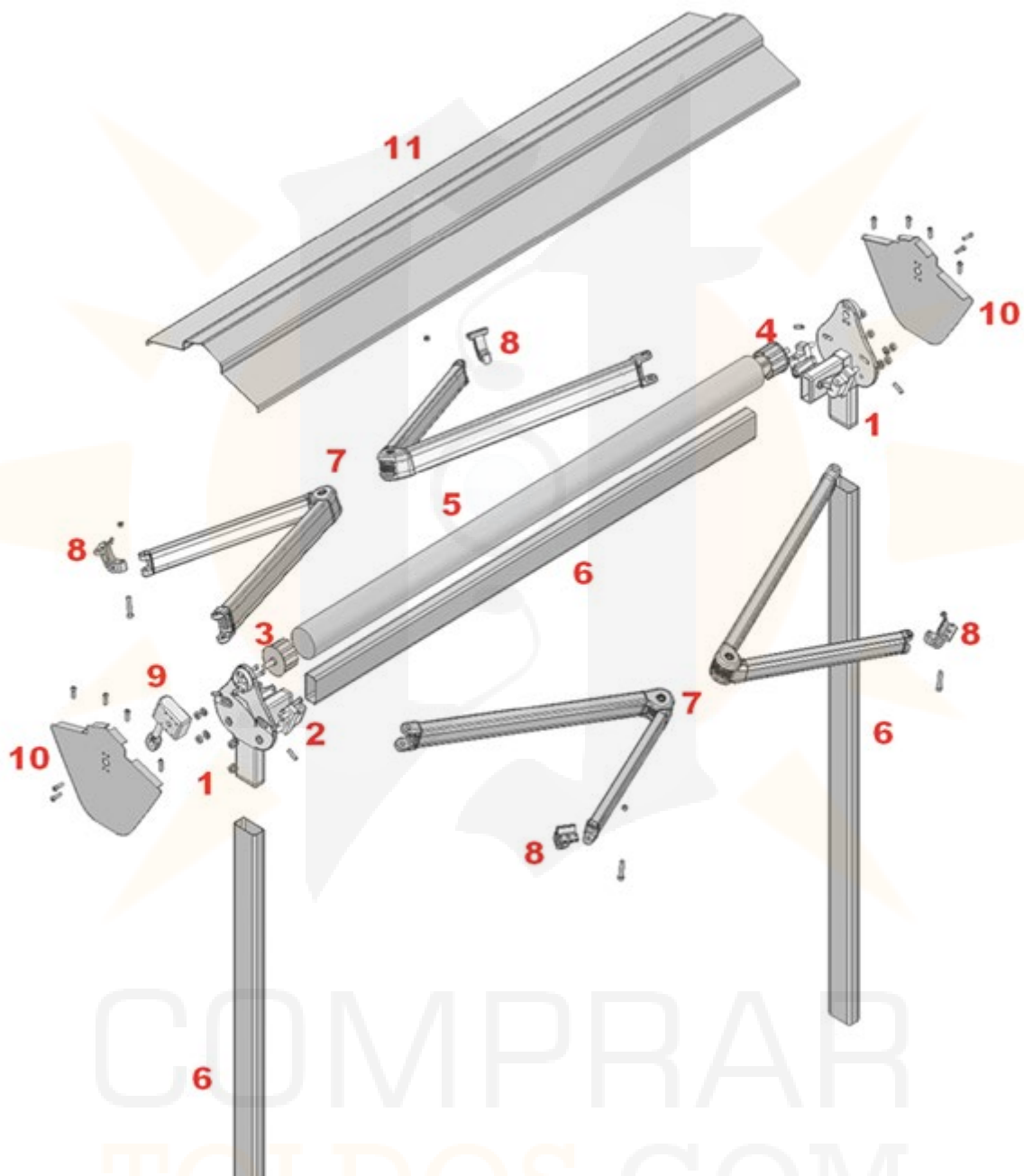

- 1: Cabezal
- 2: Rótula
- 3: Casquillo punta máquina
- 4: Casquillo con eje
- 5: Tubo enroll
- 6: Perfil hierro 80x40
- 7: Brazo
- 8: Terminal Cazorla
- 9: Máquina
- 10: Tapa tejadillo
- 11: Tejadillo



- 1: Head
- 2: Toggle
- 3: Point/machine valve holder
- 4: Valve holder with axis
- 5: Rolling tube
- 6: 80x40 Iron pipe
- 7: Arm
- 8: Cazorla Terminal
- 9: Machine
- 10: Roof tap
- 11: Roof



- 1: Tête
- 2: Rotule
- 3: Douille pointe/machine
- 4: Douille avec axe
- 5: Tube d'enroulement
- 6: Tuyau de Fer 80x40
- 7: Bras
- 8: Terminal Cazorla
- 9: Machine
- 10: Cache marquise
- 11: Marquise



- 1: Kopf
- 2: Kugelgelenk
- 3: Buchse Stift/Maschine
- 4: Buchse mit Achse
- 5: Tuchwalze
- 6: Eisenrohr 80x40
- 7: Arm
- 8: Terminal Cazorla
- 9: Getriebe
- 10: Abdeckungen Schutzdach
- 11: Schutzdach

Ref.: 108300\_\_



Kit Dúplex  
Dúplex Kit  
Kit Dúplex  
Kit Duplex

Ref.: 7116\_\_



Máquina Siplano 1.16  
1.16 Siplan Machine  
Machine Siplan 1.16  
Getriebe Siplan 1.16

Ref.: 909060\_\_



Tubo de Hierro 80 x 40 x 2 Galvanizado y Lacado  
80 x 40 x 2 Galvanized and Lacquered Iron Pipe  
Tuyau de Fer 80 x 40 x 2 Galvanisé et Laqué  
Verzinktes und lackiertes Stahltragrohr 80 x 40 x 2

Ref.: 108100\_\_



Soporte Pie Siplano Dúplex  
Siplano Dúplex Foot Support  
Maintien du Pied Siplano Dúplex  
Sockel Siplano Duplex

Ref.: 108000\_\_



Cabezal Siplano Dúplex  
Siplano Dúplex Head  
Tête Siplano Dúplex  
Kopf Siplano Dúplex

Ref.: 108200\_\_

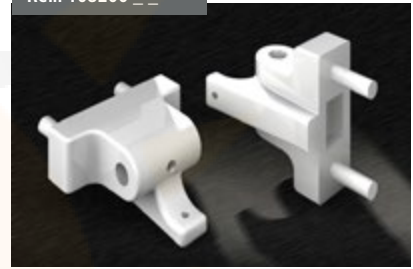

Rótula Siplano Dúplex  
Siplano Dúplex Toggle  
Rotule Siplano Dúplex  
Kugelgelenk Siplano Dúplex

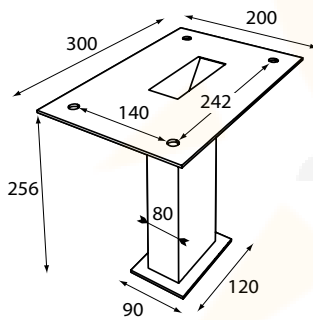

Ref.: 971050\_\_



Tejadillo Siplano Dúplex (chapa galvanizada)  
Longitud disponible 5,00 m.  
Siplano Duplex Roof (galvanized plate)  
Available Length 5,00 m.  
Siplano Duplex toit (tôle galvanisée)  
Disponible Longueur 5,00 m.  
Siplano Duplex Dach (verzinktem Blech)  
Verfügbare Länge 5,00 m.

Ref.: 108500\_\_



Juego Tapas Tejadillo Siplano Dúplex (aluminio)  
Siplano Duplex Roof Taps Kit (aluminium)  
Jeu de Caches Marquise Siplano Duplex (aluminium)  
Set Abdeckungen Siplano Duplex aluminiumschutzdach

MEDIDA DE CORTE DEL TEJADILLO MEASURE OF ROOF CUTTING MESURE DE TOIT COUPE MASS DER DACHSCHNEIDE		
TEJADILLO ROOF TOIT DACH	MANUAL MANUEL HANDBETRIEB	MOTOR SIN SOPORTE MOTOR WITHOUT SUPPORT MOTEUR SANS SUPPORT MOTOR OHNE HALTER
	LT+125mm	LT+75mm

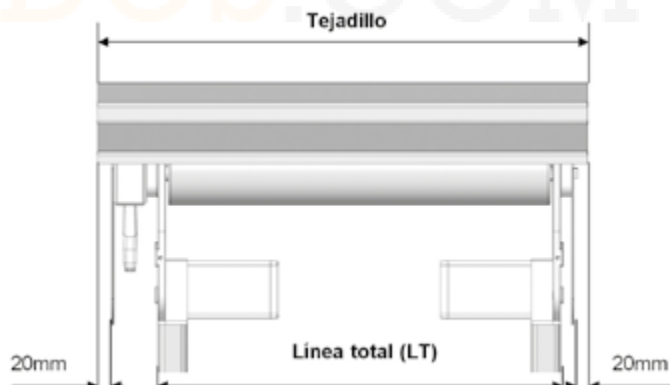

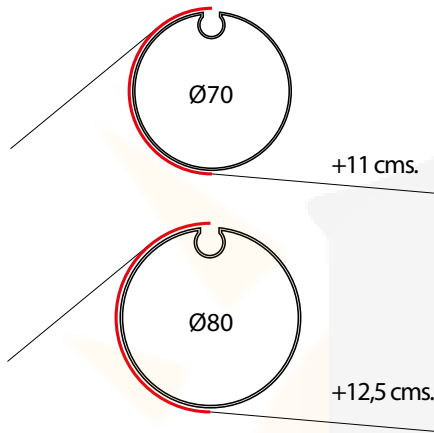

Sistema de enrollado con 1 ranura para dos lonas. La lona interior tendrá un tamaño superior según medidas del dibujo al tener un mayor recorrido que la exterior.

Rolling system with 1 slot for two canvases. The interior will have a canvas upper size as measured from drawing to have more travel than the outside.

Enroulement système avec 1 emplacement pour les deux toiles. L'intérieur aura une toile de taille supérieure, mesurée à partir de dessin pour avoir plus Voyage de l'extérieur.

Walzenrohr mit 1 Nut. Doppeltuch das innere Tuch ist länger, das äußere Tuch etwas kürzer.

LINEAS MÍNIMAS (tapas incluidas) MINIMUM LINES (caps included) MINIMAL DE LIGNES (tapas dont) MINDESTMASSE (inkl. Abdeckungen)						
<b>SALIDA BRAZO (m)</b> ARM PROJECTION AVANCÉE BRAS ARMAUSGANG	1,5	1,75	2	2,25	2,5	2,75
<b>LINEAS MÍNIMAS - MÁQUINA (m)</b> MINIMUM LINES - MACHINE MINIMAL DE LIGNES - MACHINE MINDESTMASSE - GETRIEBE	1,92	2,17	2,42	2,69	2,94	3,19
<b>LINEAS MÍNIMAS - MOTOR (m)</b> MINIMUM LINES - MOTOR MINIMAL DE LIGNES - MOTEUR MINDESTMASSE - MOTOR	1,87	2,12	2,37	2,64	2,89	3,14

ABACO DE MOTORES (salida hasta 2,75 m) MOTOR ABACO (Even Projection 2,75 m.) - ABACO MOTEUR (avancée jusqu'à 2,75 m.) MOTORABAKUS (ausfahren bis zu 2,75 m)							
* Ejes de enrollamiento diámetro 70 y 80 mm Rolling axis diameter 70 and 80 mm. - Diamètre axe d'enroulement 70 et 80 mm. Tuchwalze Durchmesser 70 und 80 mm.							
<b>Ø70</b>	<b>SALIDA (m)</b> PROJECTION AVANCÉE AUSFAHREN	1,5	1,75	2	2,25	2,50	2,75
	<b>LÍNEA HASTA 5 m. 4 BRAZOS</b> LINE UP TO 5 m. 4 arms LIGNE JUSQU'À 5 m. 4 bras LINIE BIS 5 m. 4 arms	55/17	55/17	55/17	70/17	70/17	70/17
<b>Ø80</b>	<b>SALIDA (m)</b> PROJECTION AVANCÉE AUSFAHREN	1,5	1,75	2	2,25	2,50	2,75
	<b>LÍNEA HASTA 5 mts. 4 BRAZOS</b> LINE UP TO 5 m. 4 arms LIGNE JUSQU'À 5 m. 4 bras LINIE BIS 5 m. 4 arms	70/17	70/17	70/17	85/17	85/17	85/17

### SISTEMA DUPLEX (corte de enrollado)

#### MONTAJE MANUAL

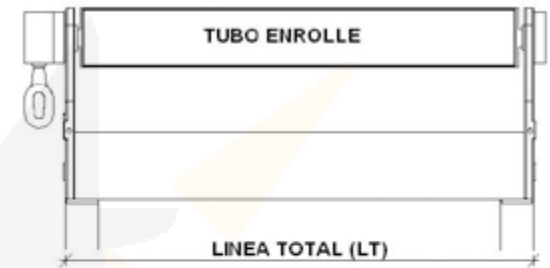

\* TUBO ENROLLE = LT - 50 mm.

#### MONTAJE MOTORIZADO

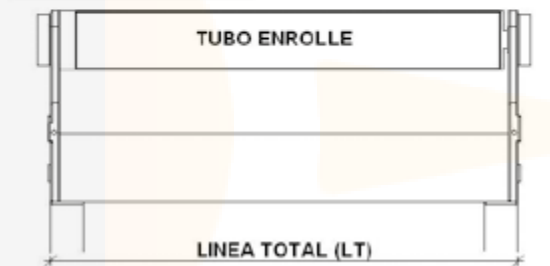

- CON SOPORTE = LT - 70 mm.

\* TUBO ENROLLE :  
- SIN SOPORTE = LT - 60 mm.

### MEDIDAS DE LOS TUBOS (no admite holguras) TUBE SIZES (not admit roominesses) MESURES DU TUBES (ne supporte pas d'habilitations) MASSE DER ROHRE (ohne Spiel)

	MANUAL MANUEL HANDBETRIEB	MOTOR SIN SOPORTE MOTOR WITHOUT SUPPORT MOTEUR SANS SUPPORT MOTOR OHNE HALTER
<b>TUBO DE ENROLLE</b> ROLLING TUBE TUBE ROULÉ TUCHWALZE	LT-50mm	LT-60mm
<b>PERFIL 80X40 HIERRO HORIZONTAL</b> HORIZONTAL 80X40 IRON PROFIL FER PROFIL 80X40 HORIZONTAL 80x40 HORIZONTAL IRON PROFIL	LT-80mm	LT-80mm

NOTA: LT= Línea total / NOTE: LT = Total line / REMARQUE: LT = Total ligne / NOTE: LT = Gesamtbreite

SALIDA (m) PROJECTION AVANCÉE AUSGANG	LÍNEA - LINE - LIGNE - LINIE					
	2,5	3	3,5	4	4,5	5
1,5						
1,75						
2						
2,25						
2,5						
2,75						

Ensayo de resistencia al viento, realizado conforme a la norma EN 13561:2004  
Wind resistance test conducted according to standard EN 13561:2004  
Vent du test de résistance menée conformément à la norme EN 13561:2004  
Windfestigkeit geprüft nach Norm EN 13561:2004

**RESISTENCIA AL VIENTO / Clasificación de producto**  
**WIND RESISTANCE / Classification of product**  
**RESISTANCE AU VENT / Classification du produit**  
**WINDFESTIGKEIT / Produktklassifizierung**

**CLASE 3** 49 Km/h. **CLASE 2** 38 Km/h. **CLASE 1** 28 Km/h.



# OMBRALSUN



OMBRALSUN, per le sue dimensioni, compattezza e facilità di installazione e regolazione, si posiziona sicuramente in vetta alla già ampia gamma dei prodotti per terrazzi e patio completandone la gamma. Grazie ad un solo tubo avvolgitore "Rollerbat" Ø 80mm, riesce a coprire una superficie di ca 36m<sup>2</sup>, mantenendo comunque contenuti gli ingombri; supporti e staffe di ancoraggio sono studiati perché tutte le installazioni siano semplici e veloci. Il sistema è completato da un cassetto integrale che racchiude, una volta ritratti, entrambi i lati della tenda.



OMBRALSUN, for its dimension, compactness and ease of installation and adjustment, is surely on top of the already wide range of products for patios and balconies. Thanks to just one roller tube "rollerbat" Ø 80mm, it can cover a surface of about 36m<sup>2</sup> Keeping anyhow limited encumbrances; supports and anchor brackets are studied to ease and speed all installations. The system is completed by a full cassette that encloses both sides of the awning, when closed.



OMBRALSUN, par ses dimensions, sa facilité d'installazion et de réglage, se positionne au sommet de la gamme de produit pour terrasse et patio. Elle est dotée d'un seul tube Ø 80mm rollerbat, elle réussit à couvrir une surface de 36m<sup>2</sup>, en ayant des encombrements réduits. Les pieds sont conçus pour une simplicité et facilité de pose. Le système est complété d'un coffre intégral, qui une fois fermé protège les deux cotés du stores



OMBRALSUN Stellt sich mit Sicherheit mit seiner Größe, Kompaktheit und einfachen Installation und Einstellung an die Spitze der schon breiten Produktangebote und vervollständigt dies für das Terrassen und Atrienangebot. Dank der nur einen Tuchwelle „Rollerbat“ Ø 80mm kann eine Fläche, mit Beibehaltung der Abmessungen, von 36m<sup>2</sup> abdecken. Die Stützen und die Verankerungshalterungen wurden für alle Anwendungsbereiche konzipiert und machen die Installation einfacher und schneller. Das System wird durch eine integrierte Kasette vervollständigt, die diese sobald sie eingezogen wird, beide Seiten der Markise umschließt.



OMBRALSUN, por sus dimensiones, terminación y facilidad de instalación y regulación, se posiciona seguramente en cabeza de la ya amplia gama de productos para terrazas y patios, completando la gama. Gracias a su único tubo de enrollle "Rollerbat" con Ø 80mm, llega a cubrir una superficie de 36m<sup>2</sup>, manteniendo, sin embargo, muy contenidas sus dimensiones; los soportes y las piezas de instalación han sido cuidadosamente estudiadas para que todas las instalaciones sean sencillas y rápidas. El sistema está completado por un cajón integral que protege, una vez recogidos, los dos lados del toldo.

# SCHEMA TECNICA

## technical sheet

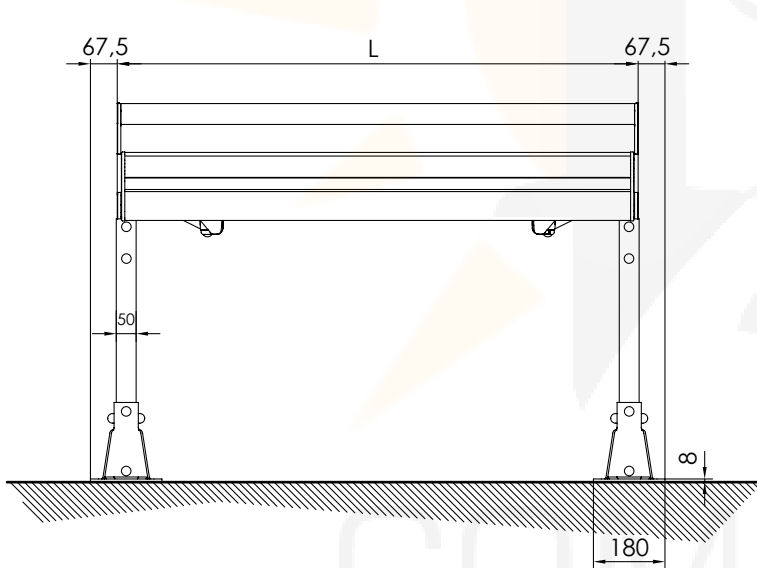
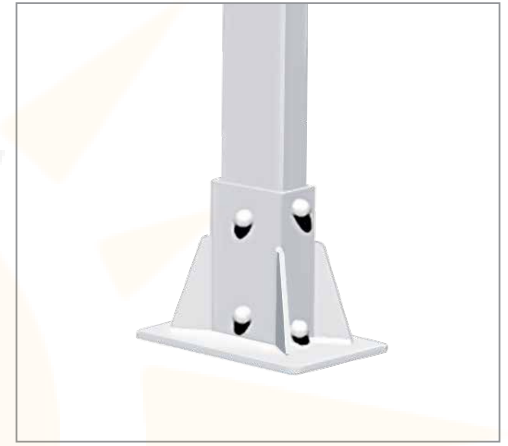
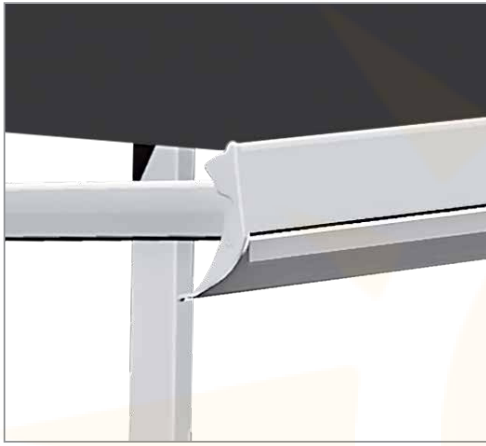

Vista frontale  
Frontal view

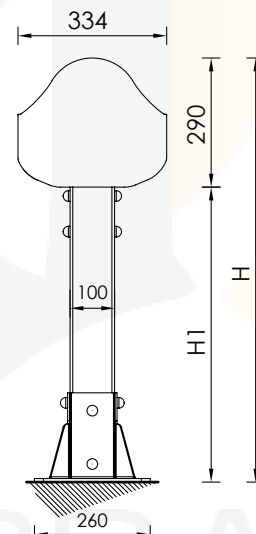

Vista laterale  
Lateral view

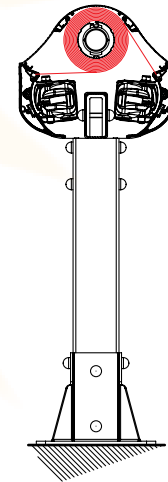

Sezione  
Section

L = larghezza tenda  
width awning

H = altezza tenda  
height awning

Dimensioni massime - Maxi dimensions



Ingombri minimi della tenda finita - 1 coppia bracci  
Minimum awning encumbrances - 1 pair arms  
Encombrents minimum du store fini - 1 pair bras  
Mindestabmessungen der Markise - 1 Paar Gelenkarme  
Tamaño mínimo del toldo - 1 pareja de brazos

Sporgenza Projection Avancée Ausladung Salida	Larghezza min. Min. Width Largeur min. Breite min. Línea mín.
160	169
210	219
260	303
310	345



### Diagramma di copertura - Covering diagram

