



# PergoSun 125



## Características y aplicaciones



Sistema con aplicación en el montaje de toldos de dimensiones grandes, para ser montado con perfil de 125x125 y guías de 125x80.

La línea máxima es 7 m.  
Salida máxima recomendada: 7 m.

## Characteristics and applications



System with application in high dimensions awning assembling, to be mounted with profiles 125x125 and guides 125x80.

Maximum length is 7 m.  
Maximum projection recommended: 7 m.

## Caractéristiques et les usages



Système avec application pour le montage de stores de grandes dimensions, montés sur un profilé de 125x125 et des tiges de guidage de 125x80.

Ligne maximum: 7 m.  
Avancée maximum recommandée: 7 m.

## Eigenschaften und Anwendungen



Montagesystem für Markisentuch mit großen Abmessungen, die mit einem Profil von 125x125 und Führungen von 125x80 montiert werden.

Maximale Linie: 7m.  
Empfohlenes maximales Ausfahren: 7 m.



# PergoSun 125

Ref.: 147700\_\_



Angular 125  
Angular 125  
Angulaire 125  
Dreifacher 125

Ref.: 1463\_\_



Guía 125x80  
Guide 125x80  
Glissière 125x80  
Führung 125x80

Ref.: 147300\_\_



Soporte L 125  
L 125 Support  
Support L 125  
L 125 Halter

Ref.: 147400\_\_

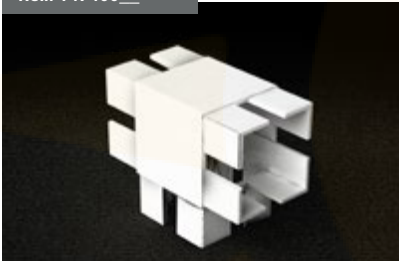

Soporte T 125  
T 125 Support  
Support T 125  
T 125 Halter

Ref.: 1462\_\_



Perfil 125x80  
Profile 125x80  
Profil 125x80  
Profil 125x80

Ref.: 1460\_\_

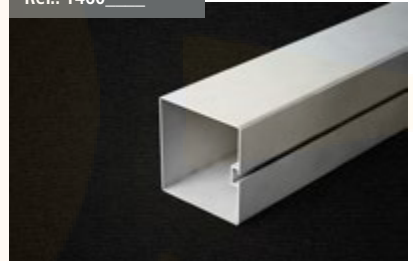

Perfil Regletero 125  
Reglet Profile 125  
Profil de Réglette 125  
Verlängerung profil 125

Ref.: 147100\_\_



Pie + 125  
Foot + 125  
Pied + 125  
Sockel + 125

Ref.: 147200\_\_



Pie L 125  
L Foot 125  
Pied L 125  
Sockel L 125

Ref.: 147600\_\_



Soporte pérgola 125 (extrusión)  
Pergola Support 125 (extrusion)  
Pergola Support 125 (extrusion)  
Halterung Pergola 125 (extrusion)

Ref.: 147500\_\_

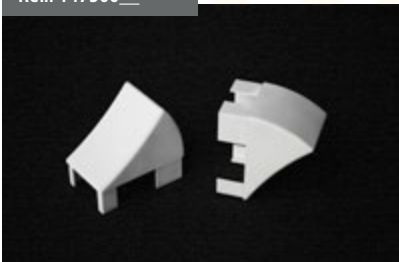

Pecho paloma 125x80  
Chest dove 125x80  
Arqué 125x80  
Zierleiste 125x80

Ref.: 147000\_\_



Tapón adaptador 125  
Adapter Plug 125  
Cache Adapter 125  
Stopfen Adapter 125



# PergoSun Eléctrico 125

## Características y aplicaciones



Sistema diseñado para motorizar todos planos con el sistema de perfiles de medida 125x80. Producto de confección y montaje fácil y rápido permitiendo un alto acabado estético y funcional del conjunto.

Medidas máximas por módulo: 7 metros de línea por 7 metros de salida con 3 guías.

Ampliable a 9 metros de salida realizando empalmes y creando una soportación para la guía

Guía y palillera de aluminio extrusionado (UNE-L337) la cual se mecaniza con correa dentada y coronas de transmisión y retorno compuestas de poliamida y fibra de vidrio.

Sistema de enganche de la correa a la polea de arrastre de fácil ensamblaje.

Mecanización totalmente oculta al ir por el interior de la guía.

Sistema silencioso al no existir roces mecánicos.

## Characteristics and applications



System designed to motorize flat awnings system profiles as 125x80. Product of clothing and quick and easy installation allowing a high aesthetic and functional finish the set.

Maximum measurements per module: line 7 meters by 7 meters projection with 3 guides.

Expandable to 9 meters carrying out joints and creating a support item for guides.

Guide and little profile made of extruded aluminium (UNE L-337) mechanized with dented belt and transmission and return crown made of polyamide and glass fibre.

Easy assembling system for joining the belt to the pulley to trailing.

The mechanization is totally occult because is covered for the guide.

It's a very silent system to avoid the mechanical friction.

## Caractéristiques et les usages



Le système est conçu pour motoriser les profils système auvents plats en 125x80. Produit de vêtements et d'installation rapide et facile Permettre une finition esthétique et fonctionnelle élevée de l'ensemble.

Mesures maximales par module: ligne 7 mètres par 7 mètres projection avec 3 glissière.

Extensible à 9 mètres transportant les joints et la création d'un élément de soutien pour glissières.

Glissière et croisillons en aluminium extrudé (UNE-L337) mécanisée par une courroie dentée et des couronnes de transmission et de retour composées de polyamide et fibre de verre.

Système d'attelage de la courroie à la poulie d'entraînement facile à assembler.

Mécanisation totalement dissimulée à l'intérieur de la glissière.

Système silencieux en raison d'absence de frottements mécaniques.

## Eigenschaften und Anwendungen



System entwickelt, um Flachmarkisen Systemprofile wie 125x80 motorisieren. Produkt von Kleidung und schnelle und einfache Montage erlauben eine hohe ästhetische und funktionale Oberfläche das Set.

Maximale Messungen pro Modul: Linie 7 x 7 Meter Projektion mit 3 führungs.

Erweiterbar auf bis zu 9 Meter Durchführung Gelenke und die Schaffung eines Unterstützungspunkt zur führungs.

Führung und Stangen aus extrudiertem Aluminium (UNE-L337), mechanisiert per Pfette, Radkränze und Rücklauf aus Polyamid und Glasfaser.

Die Pfette kann leicht an die Zuglaufrolle angehängt werden.

Die Mechanisierung im Innern der Führung ist vollständig verdeckt.

Lautloses System ohne mechanische Reibungen.

LINEA TOLDO AWNING LINE - AUVENT EN LIGNE - LINIE DER MARKISE		
<b>SALIDA (m)</b> PROJECTION AVANCEE AUSFAHREN	7	9
<b>LÍNEA HASTA 7 m.</b> LINE UP TO 7 m. LIGNE JUSQU'À 7 m. LINIE BIS 7 m.	30/17	40/17
<b>LÍNEA HASTA 12 m.</b> LINE UP TO 12 m. LIGNE JUSQU'À 12 m. LINIE BIS 12 m.	70/17	85/17

Ref.: 148100



Correa Dentada  
Dented belt

Courroie Dentée  
Pfette

Ref.: 148000

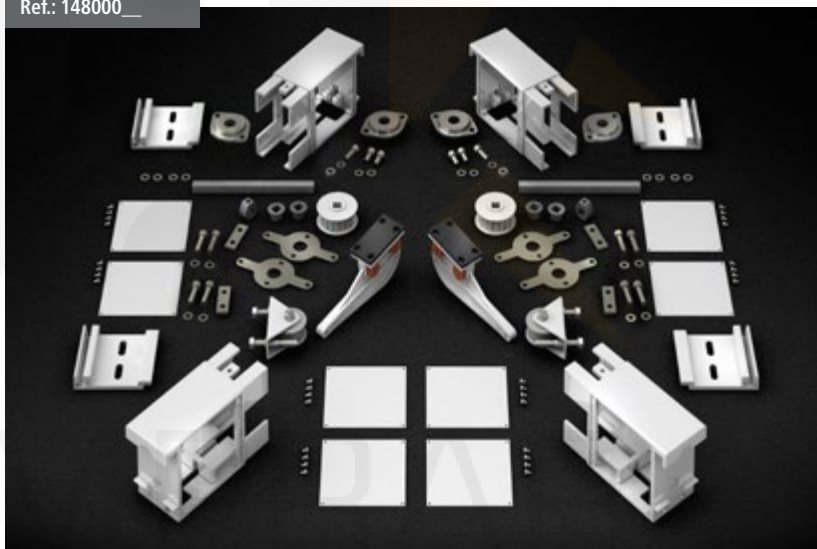

Conjunto Motor 125x80 (incluye escuadras y casquillos)  
Kit Motor 125x80 (valve holders included)  
Ensemble Moteur 125x80 (comprend équerres et douilles)  
Motoreinheit 125x80 (inkl. Winkel und Buchsen)

Ref.: 1463



Guía 125x80  
Guide 125x80  
Glissière 125x80  
Führung 125x80



# PergoSun Eléctrico 125

Despiece - Electric PergoSun parts - Pièces de Pergosun électrique - Komponenten der Elektrisch PergoSun

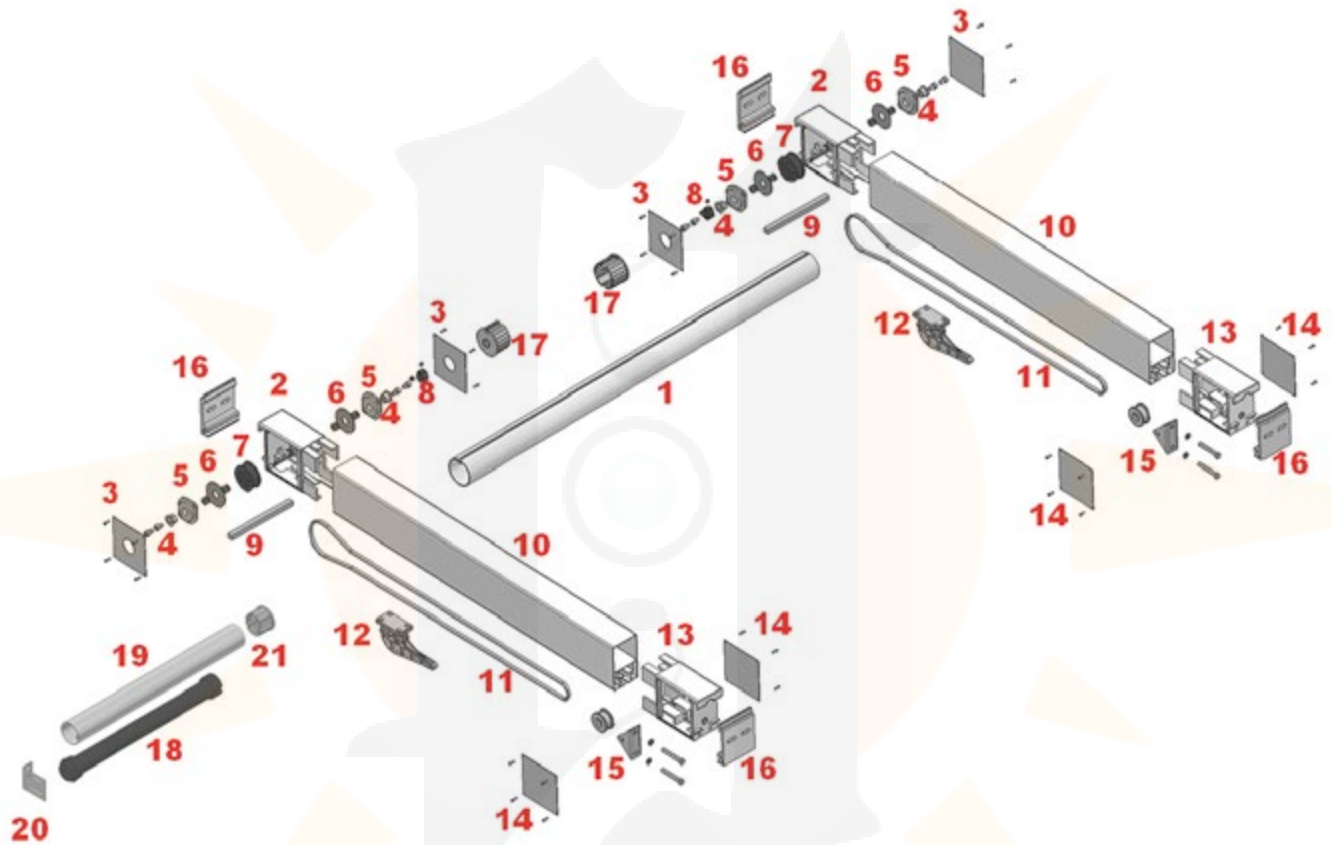

- 1: Tubo de transmisión 70mm
- 2: Soporte motriz
- 3: Tapa soporte motriz
- 4: Adaptador eje de 13mm
- 5: Rodamiento
- 6: Acople intermedio
- 7: Polea motriz
- 8: Freno eje de 13mm
- 9: Eje cuadrado de 13mm
- 10: Guía 125x80
- 11: Correa
- 12: Polea de arrastre
- 13: Soporte retorno
- 14: Tapa soporte retorno
- 15: Tensor
- 16: Placa pared
- 17: Casquillo tubo de transmisión
- 18: Motor
- 19: Tubo de enrollado 78mm
- 20: Soporte motor
- 21: Casquillo enrollado 78mm



- 1: Transmission tube 70 mm.
- 2: Motor support
- 3: Motor support cap
- 4: Axis Adapter 13 mm.
- 5: Bearing
- 6: Intermediate Coupling
- 7: Motor pulley
- 8: 13mm Axis brake
- 9: 13mm square axis
- 10: Guide 125x80
- 11: Belt
- 12: Trailing pulley
- 13: Return support
- 14: Return support cap
- 15: Tensor
- 16: Wall plate
- 17: Transmission Valve Holder
- 18: Motor
- 19: Rolling tube 78mm
- 20: Motor support
- 21: Rolling Valve holder 78mm



- 1: Tube de transmission 70 mm.
- 2: Support moteur
- 3: Cache support moteur
- 4: Axe Adapter 13 mm.
- 5: Roulement
- 6: Raccord intermédiaire
- 7: Poulie de moteur
- 8: Frein d'axe 13mm
- 9: Axe carré 13mm
- 10: Glissière 125x80
- 11: Courroie
- 12: Poulie d'entraînement
- 13: Support retour
- 14: Cache Support retour
- 15: tenseur
- 16: Plaque mur
- 17: Douille de Transmission
- 18: Moteur
- 19: Profil d'enroulement 78mm
- 20: Support moteur
- 21: Douille d'enroulement 78mm



- 1: Antriebsrohr 70 mm.
- 2: Antriebshalterung
- 3: Abdeckung der Antriebshalterung
- 4: Achse Adapter 13 mm.
- 5: Metallwälzlager
- 6: Zwischen Querstrebgarnitur
- 7: Motorriemenscheibe
- 8: Achse Brems 13mm
- 9: Platz Achse 13mm
- 10: Führung 125x80
- 11: Pfette
- 12: Zuglaufrolle
- 13: Rücklaufhalterung
- 14: Abdeckung der Rücklaufhalterung
- 15: Tensor
- 16: Wandplatte
- 17: Antriebsbuchsen
- 18: Motor
- 19: Tuchwalze 78mm
- 20: Antriebshalterung
- 21: Rollventilhalterung 78mm