



Versatilità.

Versatility - Vielseitigkeit - Polyvalence- Versatilidad

Eleganza.

Elegance - Eleganz - Élégance - Elegancia

Praticità.

Convenience - Funktionalität - Fonctionnalité - Funcionalidad

Qualità.

Quality - Qualität - Qualité - Calidad

Vasta gamma di tessuti

Wide range of fabrics
Stoffauswahl für abzudeckende
Gamme de tissus
Gama de tejidos

Sistemi di fissaggio per ogni tipo di superficie.

Fixing systems for each type of surface - Befestigungssysteme für jeden Untergrund - Systèmes de fixation pour tout type de surface - Sistemas de fijación para diferentes superficies

Sistemi di tensionamento per ogni esigenza.

Tensioning systems for every need - Spannungssysteme für jeden Bedarf - Systèmes de tension pour tous les configurations - Sistemas de tensionado según exigencias

Sù misura

Customized - Auf Maß - Personalisé - A medida





**COMPRAR
TOLDOS.COM**

SAILS

GENNIUS SAILS S1

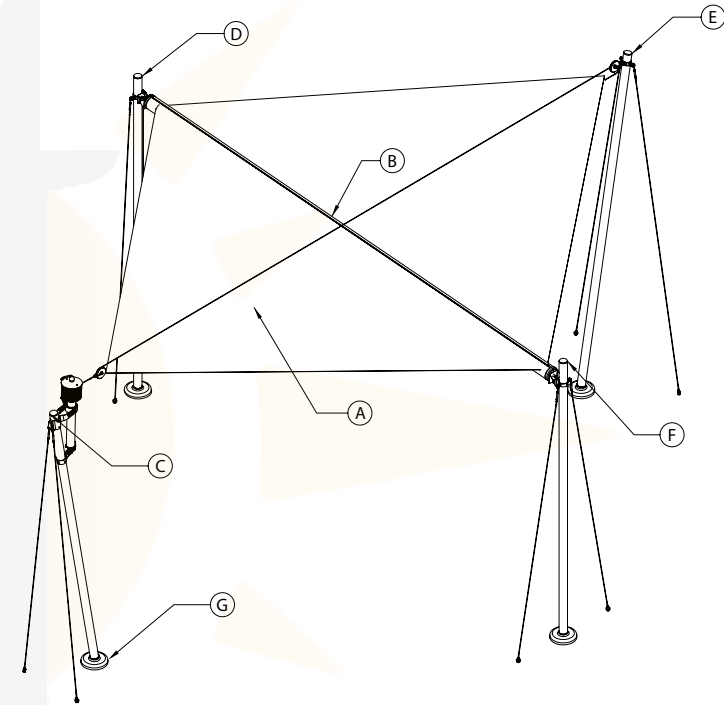
VELAS MOTORIZADAS



 Sistema ombreggiante a vela motorizzato, completo di struttura a 4 alberi portanti in acciaio inox 316, tensionamento con funi in acciaio inox aisi 316, tessuto a scelta (Dacron laminato, Soltis 92, Tempotest Star Tempotest Star Light) avvolto su boma centrale in alluminio anodizzato. Resistenza al vento garantita fino alla classe 2 secondo la UNI EN 13561. Struttura non adatta alla tenuta all'acqua e al carico di neve. La formazione di condensa sul telo non è da considerarsi difetto, si tratta di un fenomeno naturale.

 Motorized sun protection sail system, made of 4 bearing masts (316 stainless steel), tightened by 316 stainless steel cables, preferred fabric (rolled Dacron, Soltis 92, Tempotest Star Tempotest Star Light) enrolled on a central anodized aluminium boom. Guaranteed wind resistance up to class 2 according to UNI EN 13561. Structure not suitable for holding water and snow loads. The development of condensation on the fabric is natural and not to be considered as a defect.

 Motorisiertes Sonnensegelsystem, besteht aus 4 Tragstützen (Edelstahl 316), Spannungssystem durch Edelstahlseilen AISI 316, Tücher nach Wahl erhältlich (Dacronlaminat, Soltis 92, Tempotest Star Tempotest Star Light), auf eine mittlere Tuchwelle aus eloxierten Aluminium Gerollt. Windbeständigkeit: Nach UNI EN 13561 bis Klasse 2 garantiert. Zum Halten von Wasser und Schneelast nicht geeignete Struktur. Die Entwicklung von Kondensation auf den Stoff ist nicht ein Defekt, sondern ist natürlich.

 Système de voile d'ombrage motorisée, intégrant 4 mats portent 5acier Inox 316), tension par câble en acier Aisi 316, tissus au choix (Dacrom laminé, Soltis 92, tempotest star Tempotest Star Light) enrôlé sur un bome central en aluminium anodisé. Résistance au vent garantie jusqu'à la classe 2 selon la norme UNI 13561. Structure non étanche à l'eau et non adaptée au poids de la neige. Le développement de condensation sur le tissu n'est pas considéré un défaut, c'est un phénomène naturel.

 Sistema de protección solar a vela motorizado, con estructura completa con 4 columnas (acero inox 316), tensionamiento con cables de acero inox aisi 316, tejido a escoger (Dacron laminado, Soltis 92, Tempotest Star Tempotest Star Light) enrollado sobre un eje central de aluminio anodizado. Resistencia al viento garantizada hasta la clase 2 según la UNI EN 13561. Estructura inadecuada para soportar el agua y el peso de la nieve. La formación de agua de condensación no es un defecto sino un fenómeno natural.

- A Telo
- B Boma
- C Albero porta motore
- D Albero porta boma con cricco
- E Albero rinvio
- F Albero porta boma folle
- G Copripiedino (optional)

- A Fabric
- B Boom
- C Drive shaft
- D Shaft boom with "ratchet"
- E Countershaft
- F Free boom shaft
- G foot coverlet (optional)

- A Tuch
- B Tuchwelle
- C Stütze mit Motor
- D Tuchwellen Trägerstütze mit Heber
- E Vorgegestütze
- F Tuchwellen Trägerstütze
- G Bodenbefestigungsdeckel (Optional)

- A Toile
- B Bome
- C Mat porte moteur
- D Mat porte bome avec cric
- E Mat renvioie
- F Mat porte bome libre
- G Cache pied (optional)

- A Tela
- B Eje
- C Columna porta motor
- D Columna porta eje cric
- E Columna reenvio
- F Columna porta eje loco
- G Cubrepies (opcional)



Schema tecnico generale/General technical plan/Allgemein - technisches Schema/Plan technique général/Dibujo tecnico general

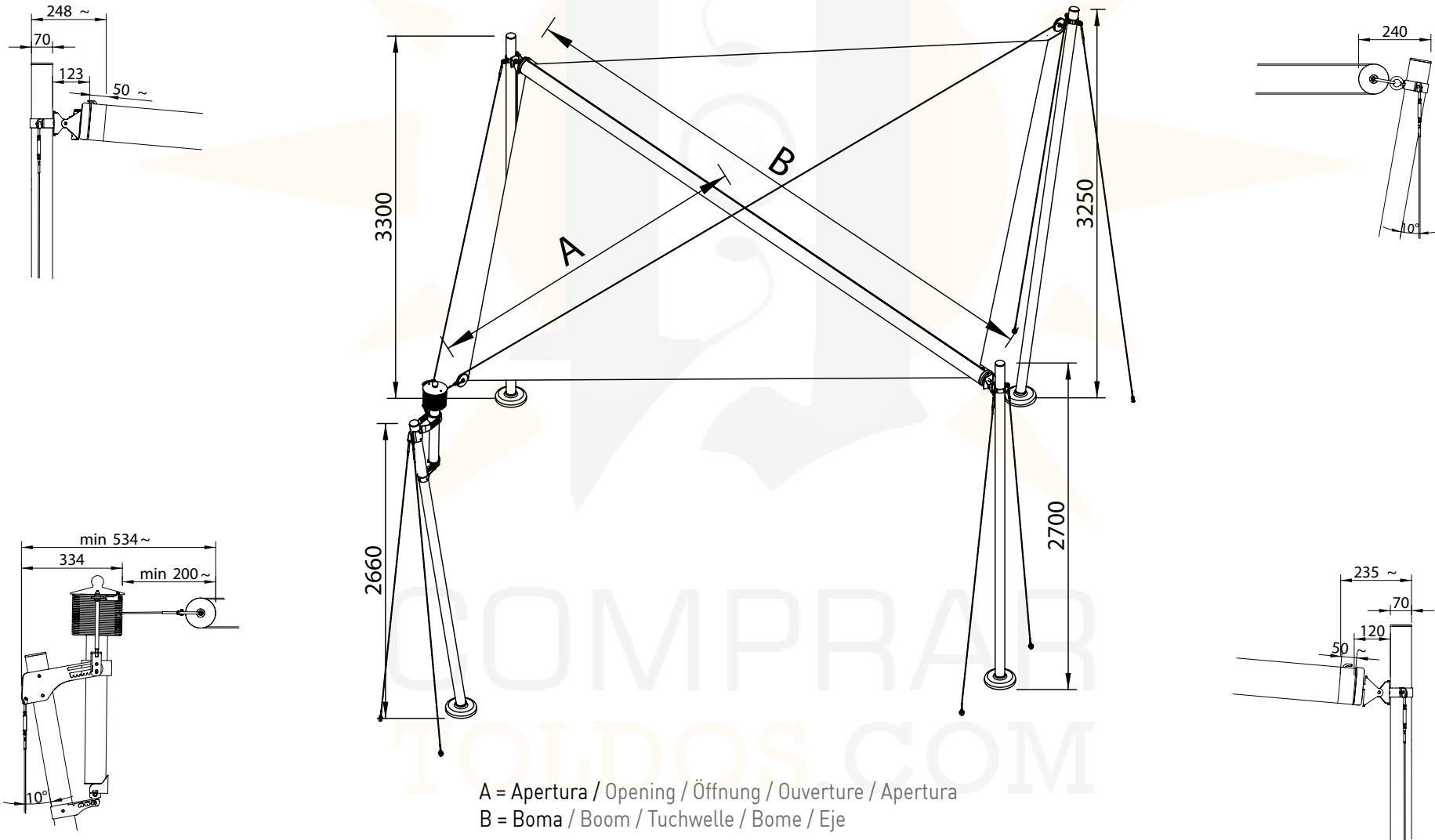



GENNIUS SAILS S1

 **A**
Apertura / Opening / Öffnung / Ouverture / Apertura

 **B**
Boma / Boom / Tuchwelle / Bome / Eje

Versione Inox / Inox version



TEMPOTEST STAR LIGHT

cm	 B	400	500	600	700	800	900	1000
 A		€						
250		7.008	7.392	7.777	8.161	8.701	9.085	9.470
300		7.234	7.674	8.113	8.553	9.146	9.586	10.024
350		7.461	7.955	8.450	8.943	9.592	10.085	10.580
400		7.687	8.236	8.785	9.334	10.037	10.586	11.135
450		7.914	8.518	9.121	9.725	10.483	11.086	11.689
500		8.141	8.799	9.457	10.115	10.928	11.586	12.244



TEMPOTEST STAR RESINATO

cm	 B	400	500	600	700	800	900	1000
 A		€						
250		7.353	7.824	8.295	8.766	9.391	9.863	10.333
300		7.649	8.192	8.735	9.278	9.975	10.518	11.061
350		7.945	8.560	9.175	9.790	10.558	11.173	11.788
400		8.240	8.928	9.615	10.302	11.142	11.829	12.516
450		8.536	9.295	10.054	10.812	11.726	12.484	13.243
500		8.833	9.663	10.494	11.324	12.309	13.140	13.970

SOLTIS 92

cm	 B	400	500	600	700
 A		€			
250		7.483	7.987	8.491	8.994
300		7.805	8.387	8.970	9.552
350		8.127	8.787	9.448	10.109
400		8.449	9.188	9.927	10.666
450		8.771	9.589	10.406	11.223
500		9.092	9.988	10.885	11.781

DACRON LAMINATO

cm	 B	400	500	600	700	800	900	1000
 A		€						
250		8.040	8.682	9.326	9.969	10.765	11.408	12.050
300		8.473	9.222	9.972	10.721	11.624	12.373	13.122
350		8.907	9.762	10.618	11.473	12.482	13.338	14.193
400		9.340	10.302	11.264	12.225	13.341	14.302	15.264
450		9.773	10.841	11.909	12.976	14.199	15.267	16.335
500		10.207	11.381	12.555	13.729	15.057	16.231	17.405

Modalità di cucitura per i tessuti
Means of sewing fabrics
Art und Weise der Naht für Stoffe
Modalités de couture pour les tissus
Tipo de costura para el tejido

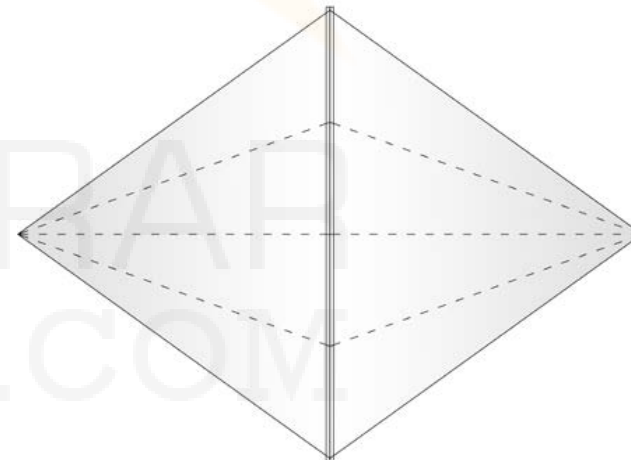



 Boma giuntato / Jointed boom / Gekoppelte Tuchwelle / Bome jointé / Eje unido

GENNIUS SAILS S2

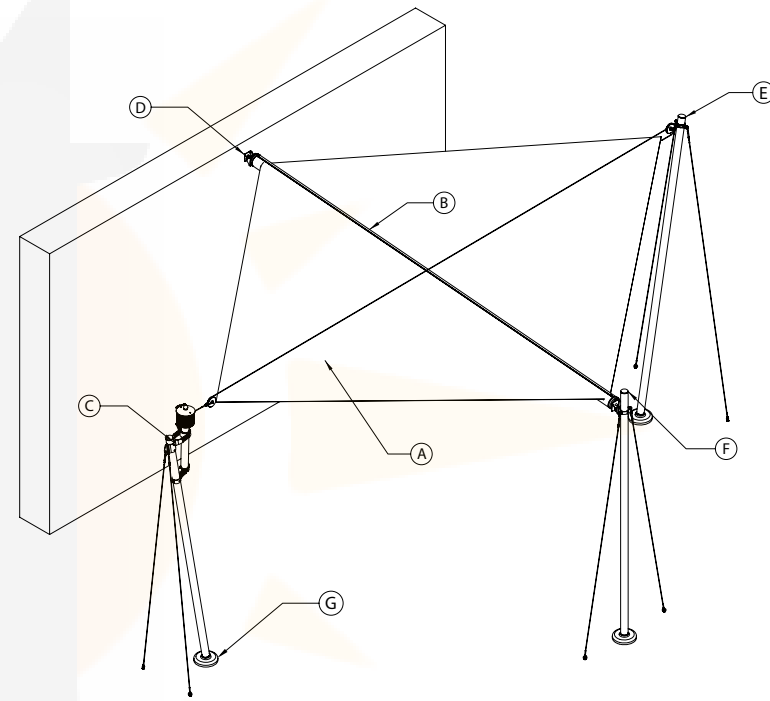
VELAS MOTORIZADAS



 Sistema ombreggiante motorizzato a vela completo di struttura con 3 alberi portanti e boma supportato a parete con staffa in acciaio inox 316, tensionamento con funi in acciaio inox aisi 316, tessuto a scelta (Dacron laminato, Soltis 92, Tempotest Star resinato, Tempotest Star Light) avvolto su boma centrale in alluminio anodizzato. Resistenza al vento garantita fino alla classe 2 secondo la UNI EN 13561. Struttura non adatta alla tenuta dell'acqua e al carico di neve. La formazione di condensa sul telo non è da considerarsi difetto, si tratta di un fenomeno naturale.
* Possibilità boma invertito da C a E

 Motorized sun protection sail system with structure made of 3 masts and boom fixed on wall with bracket (316 stainless steel), tightened by 316 stainless steel cables, preferred fabric (rolled Dacron, Suncontrol, Tempotest Star, Tempotest Star Light) enroled on a central anodized aluminium boom. Guaranteed wind resistance up to class 2 according to UNI EN 13561. Structure not suitable for holding water and snow loads. The development of condensation on the fabric is natural and not to be considered as a defect.
* Inverted boom possibilities from C to E

 Motorisiertes Sonnensegelsystem, besteht aus 3 Tragstützen mit Konsolen (Edelstahl 316), Tuchwelle an der Wand befestigt, Spannungssystem durch Edelstahlseilen AISI 316, Tücher nach Wahl erhältlich (Dacronlaminat, Suncontrol, Tempotest Star, Tempotest Star Light), auf eine mittlere Tuchwelle aus eloxierten Aluminium gerollt. Windbeständigkeit: Nach UNI EN 13561 bis Klasse 2 garantiert. Zum Halten von Wasser und Schneelast nicht geeignete Struktur. Die Entwicklung von Kondensation auf den Stoff ist nicht ein Defekt, sondern ist natürlich.
* Umdrehmöglichkeit der Wickelwelle von C nach E

 Système de voile d'ombrage motorisée, intégrant 3 mats portant avec support bome mural avec support (acier Inox 316), tension par cable en acier Aisi 316, tissus au choix (Dacrom laminé, Sunavectrol microperforée, tempotest star, Tempotest Star Light) enrôlé sur un bome central en aluminium anodisé. Résistance au vent garantie jusqu'à la classe 2 selon la norme UNI 13561. Structure non étanche à l'eau et non adaptée au poids de la neige. Le développement de condensation sur le tissu n'est pas considéré un défaut, c'est un phénomène naturel.
* Possibilité boma inversée de C à E

 Sistema de protección solar motorizado a vela con estructura con 3 columnas portantes y eje instalado a pared con soporte (acero inox 316), tensionamiento con cables de acero inox aisi 316, tejido a escoger (Dacron laminado, Suncontrol, Tempotest Star resinado, Tempotest Star Light) enrollado sobre eje central de aluminio anodizado. Resistencia al viento garantizada hasta la clase 2 según la UNI EN 13561. Estructura inadecuada para soportar el agua y el peso de la nieve. La formación de agua de condensación no es un defecto sino un fenómeno natural.
* posibilidad de invertir el eje de la posición de C a E

- A Telo
- B Boma
- C Albero porta motore
- D Staffa porta boma con cricco
- E Albero rinvio
- F Albero porta boma folle
- G Copripiedino (optional)

- A Fabric
- B Boom
- C Drive shaft
- D Bracket boom with "ratchet"
- E Countershaft
- F Free boom shaft
- G foot coverlet (optional)

- A Tuch
- B Tuchwelle
- C Stütze mit Motor
- D Konsolen-Trägerstütze mit Heber
- E Vorgeleestütze
- F Tuchwellen-Trägerstütze
- G Bodenbefestigungsdeckel (Optional)

- A Toile
- B Bome
- C Mat porte moteur
- D Support porte bome avec cric
- E Mat renvoie
- F Mat porte bome libre
- G Cache pied (optional)

- A Tela
- B Eje
- C Columna porta motor
- D Soporte porta eje cric
- E Columna reenvio
- F Columna porta eje loco
- G Cubrepies (opcional)



Schema tecnico generale/General technical plan/Allgemein - technisches Schema/Plan technique général/Dibujo tecnico general

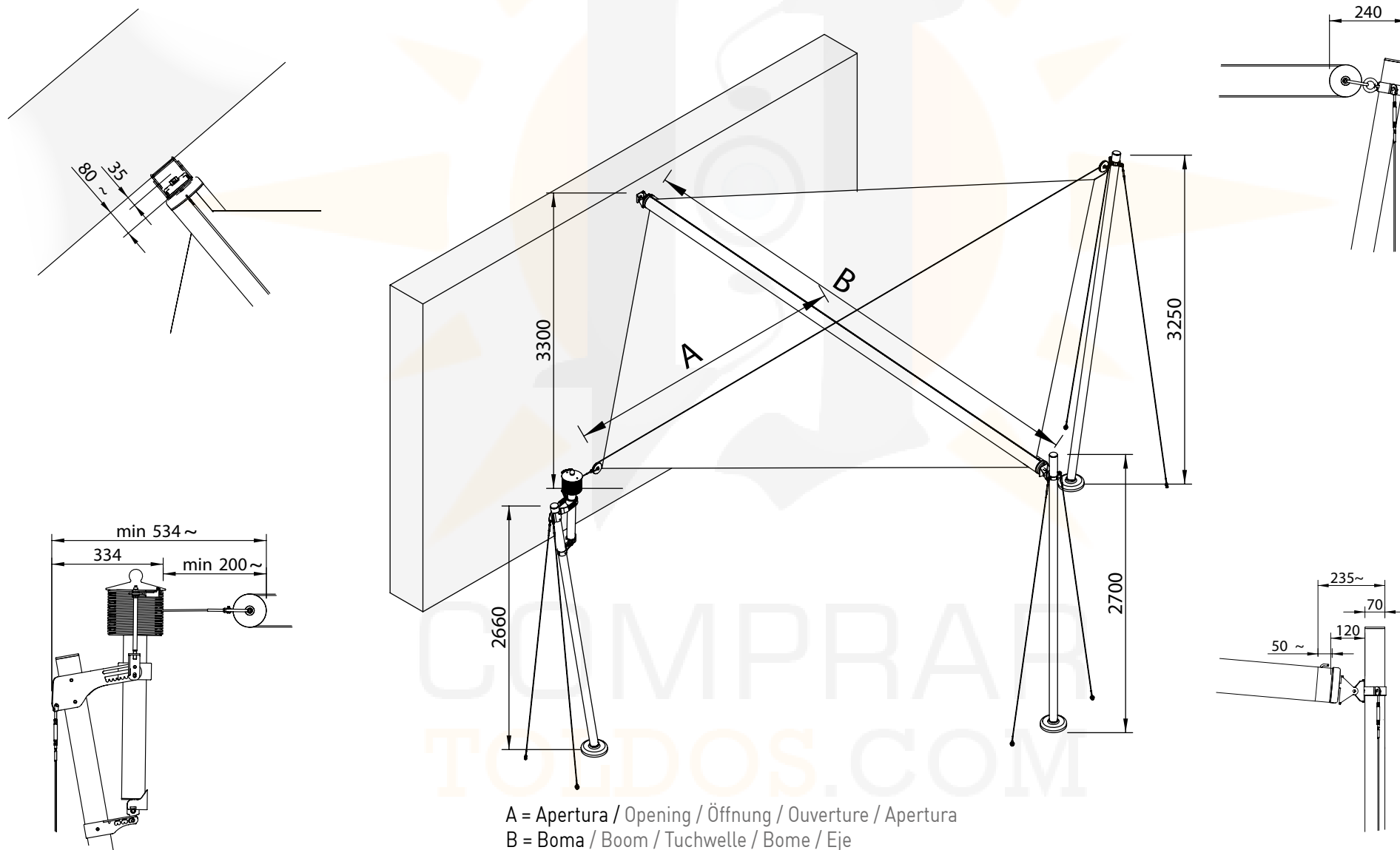



GENNIUS SAILS S2

 **A**
Apertura / Opening / Öffnung / Ouverture / Apertura



 **B**
Boma / Boom / Tuchwelle / Bome / Eje

Versione Inox / Inox version



TEMPOTEST STAR LIGHT

cm	 B	400	500	600	700	800	900	1000
 A		€						
250		5.633	5.907	6.179	6.453	6.726	6.999	7.273
300		5.852	6.179	6.508	6.836	7.164	7.492	7.820
350		6.070	6.453	6.836	7.219	7.601	7.984	8.367
400		6.289	6.726	7.164	7.601	8.039	8.476	8.914
450		6.508	6.999	7.492	7.984	8.476	8.969	9.460
500		6.726	7.273	7.820	8.367	8.914	9.460	10.007



TEMPOTEST STAR RESINATO

cm	 B	400	500	600	700	800	900	1000
 A		€						
250		6.634	7.104	7.576	8.047	8.672	9.143	9.615
300		6.929	7.472	8.016	8.559	9.256	9.799	10.342
350		7.226	7.841	8.456	9.071	9.839	10.454	11.069
400		7.522	8.209	8.895	9.582	10.423	11.110	11.797
450		7.817	8.576	9.334	10.093	11.006	11.765	12.524
500		8.113	8.944	9.774	10.605	11.590	12.421	13.251

SOLTIS 92

cm	 B	400	500	600	700
 A		€			
250		6.765	7.268	7.771	8.274
300		7.086	7.668	8.250	8.832
350		7.408	8.068	8.729	9.389
400		7.730	8.469	9.208	9.946
450		8.052	8.869	9.687	10.504
500		8.373	9.269	10.166	11.062

DACRON LAMINATO

cm	 B	400	500	600	700	800	900	1000
 A		€						
250		7.321	7.963	8.606	9.249	10.046	10.689	11.332
300		7.754	8.503	9.252	10.002	10.904	11.654	12.403
350		8.187	9.043	9.898	10.754	11.763	12.618	13.474
400		8.621	9.583	10.544	11.506	12.621	13.583	14.545
450		9.054	10.122	11.189	12.257	13.480	14.548	15.615
500		9.487	10.661	11.835	13.009	14.338	15.512	16.686

Modalità di cucitura per i tessuti
Means of sewing fabrics
Art und Weise der Naht für Stoffe
Modalités de couture pour les tissus
Tipo de costura para el tejido

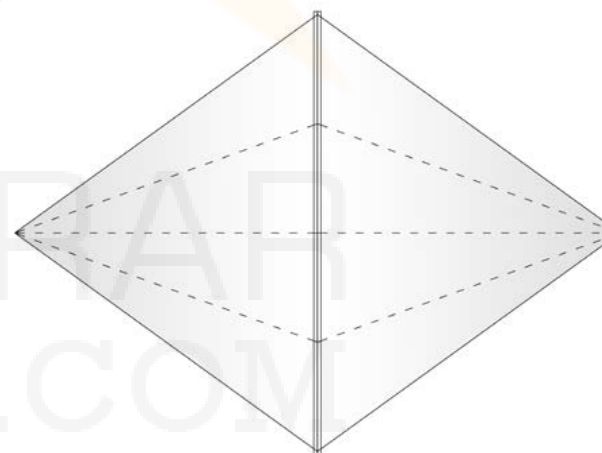

 Boma giuntato / Jointed boom / Gekoppelte Tuchwelle / Bome jointé / Eje unido

GENNIUS SAILS S3

VELAS MOTORIZADAS

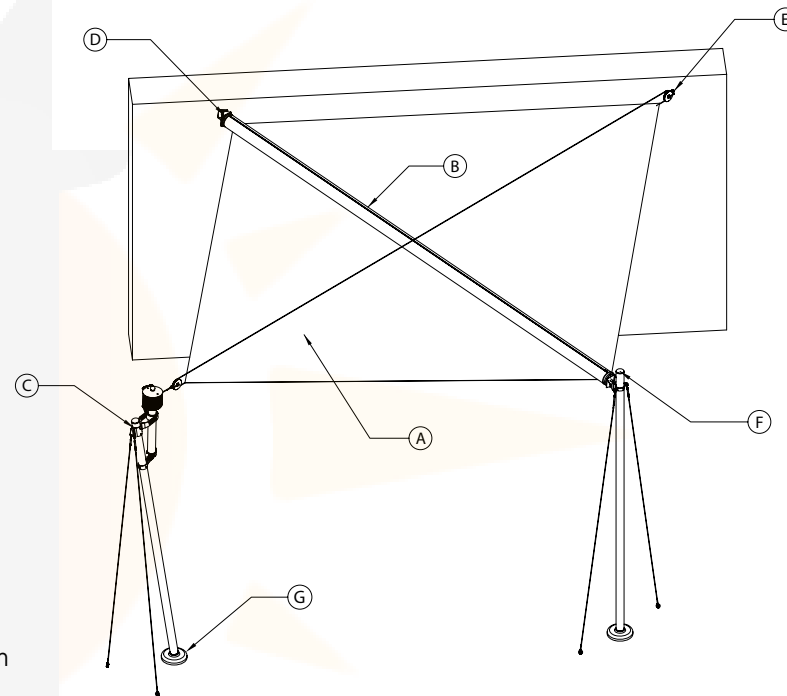

 Sistema ombreggiante motorizzato a vela completo di struttura con 2 alberi portanti, boma e rinvio a parete con staffe in acciaio inox 316, tensionamento con funi in acciaio inox aisi 316, tessuto a scelta (Dacron laminato, Soltis 92, Tempotest Star resinato, Star Light) avvolto su boma centrale in alluminio anodizzato.

Resistenza al vento garantita fino alla classe 2 secondo la UNI EN 13561.

Struttura non adatta alla tenuta dell'acqua e al carico di neve.

La formazione di condensa sul telo non è da considerarsi difetto, si tratta di un fenomeno naturale.

* Possibilità boma invertito da C a E

 Motorized sun protection sail system, made of 2 bearing masts, boom and wall return device with bracket (316 stainless steel), tightened by 316 stainless steel cables, preferred fabric (rolled Dacron, Soltis 92, Tempotest Star, Star Light) enroled on a central anodized aluminium boom.

Guaranteed wind resistance up to class 2 according to UNI EN 13561.

Structure not suitable for holding water and snow loads.

The development of condensation on the fabric is natural and not to be considered as a defect.

* Inverted boom possibilities from C to E

A Fabric
B Boom
C Drive shaft
D Bracket boom with "ratchet"
E Return bracket
F Free boom shaft
G foot coverlet (optional)

 Motorisiertes Sonnensegelsystem, besteht aus 2 Tragstützen mit Konsolen (Edelstahl 316), Tuchwelle und Vorgelege an der Wand befestigt, Spannungssystem durch Edelstahlseilen AISI 316, Tücher nach Wahl erhältlich (Dacronlaminat, Soltis 92, Tempotest Star, Star Light), auf eine mittlere Tuchwelle aus eloxierten Aluminium gerollt.

Windbeständigkeit: Nach UNI EN 13561 bis Klasse 2 garantiert.

Zum Halten von Wasser und Schneelast nicht geeignete Struktur.

Die Entwicklung von Kondensation auf den Stoff ist nicht ein Defekt, sondern ist natürlich.

* Umdrehmöglichkeit der Wickelwelle von C nach E

A Tuch
B Tuchwelle
C Stütze mit Motor
D Konsolen Trägerstütze mit Heber
E Rückholkonsole
F Tuchwellen Trägerstütze
G Bodenbefestigungsdeckel (Optional)

 Système de voile d'ombrage motorisée, intégrant 2 mats portant avec 2 supports bome muraux avec supporte (acier inox 316), tension par câble en acier Aisi 316, tissus au choix (Dacrom laminé, Soltis 92, tempotest star, Star Light) enroulé sur un bome central en aluminium anodisé.

Résistance au vent garantie jusqu'à la classe 2 selon la norme UNI 13561.

Structure non étanche à l'eau et non adaptée au poids de la neige.

Le développement de condensation sur le tissu n'est pas considéré un défaut, c'est un phénomène naturel.

* Possibilité boma inversée de C à E

A Toile
B Bome
C Mat porte moteur
D Supporte porte bome avec cric
E Support renvoi
F Mat porte bome libre
G Cache pied (optional)

 Sistema de protección solar motorizado a vela con estructura con 2 columnas portantes, eje y reenvio a pared con soporte (acero inox 316), tensionamiento con cables de acero inox aisi 316, tejido a escoger (Dacron laminado, Soltis 92, Tempotest Star resinado, Star Light) enrollado sobre eje central de aluminio anodizado.

Resistencia al viento garantizada hasta la clase 2 según la UNI EN 13561.

Estructura inadecuada para soportar el agua y el peso de la nieve.

La formación de agua de condensación no es un defecto sino un fenómeno natural.

* Posibilidad de invertir el eje de la posición de C a E

A Tela
B Eje
C Columna porta motor
D Soporte porta eje cric
E Soporte reenvio
F Columna porta eje loco
G Cubrepies (opcional)

A Telo
B Boma
C Albero porta motore
D Staffa porta boma con cricco
E staffa rinvio
F Albero porta boma folle
G Copripiedino (optional)



Schema tecnico generale/General technical plan/Allgemein - technisches Schema/Plan technique général/Dibujo tecnico general

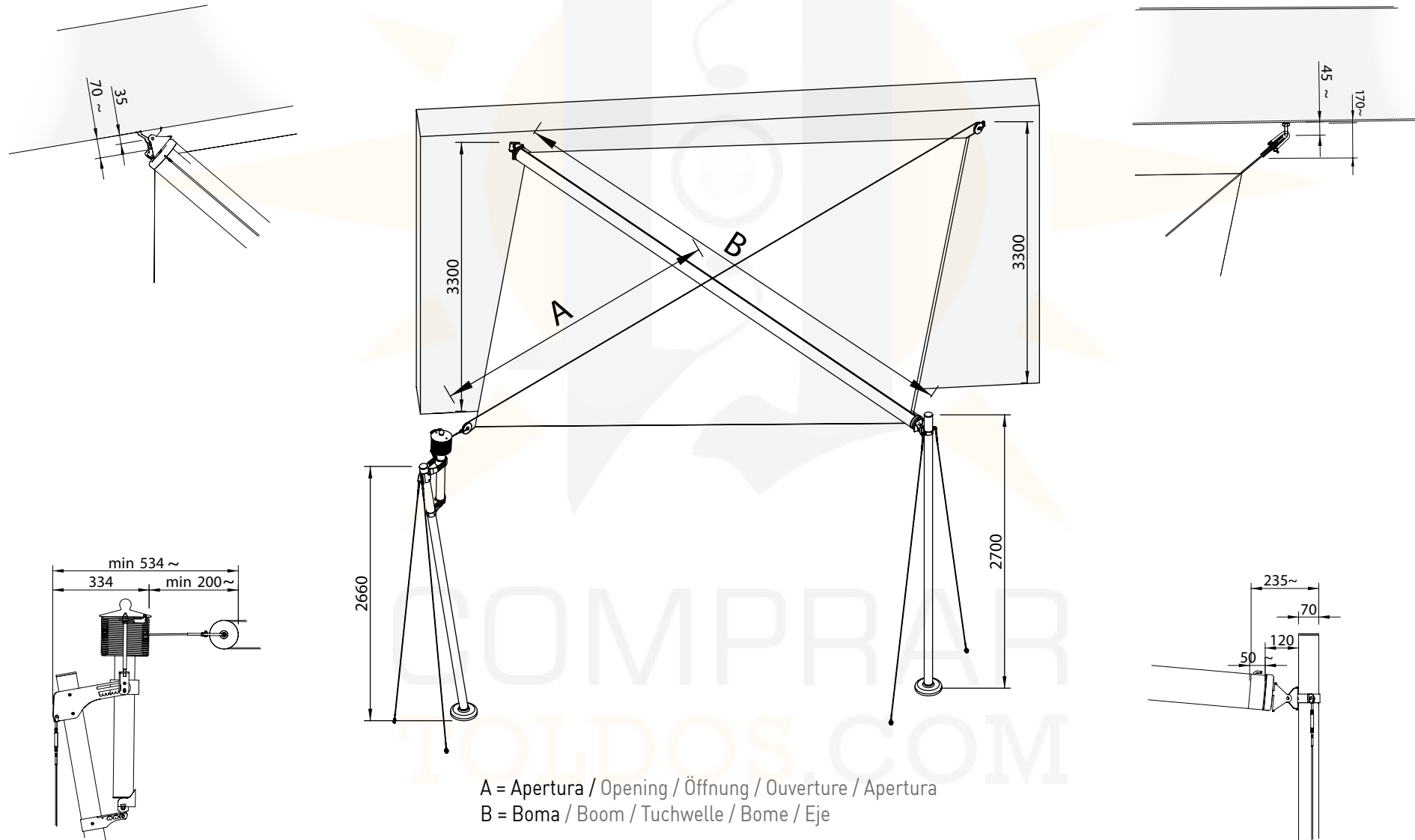



GENNIUS SAILS S3

 **A**
Apertura / Opening / Öffnung / Ouverture / Apertura



 **B**
Boma / Boom / Tuchwelle / Bome / Eje

Versione Inox / Inox version



TEMPOTEST STAR LIGHT

cm	 B	400	500	600	700	800	900	1000
 A		€						
250		4.941	5.215	5.488	5.762	6.035	6.309	6.582
300		5.161	5.488	5.817	6.144	6.473	6.801	7.129
350		5.379	5.762	6.144	6.528	6.911	7.293	7.676
400		5.598	6.035	6.473	6.911	7.347	7.785	8.223
450		5.817	6.309	6.801	7.293	7.785	8.278	8.770
500		6.035	6.582	7.129	7.676	8.223	8.770	9.316

TEMPOTEST STAR RESINATO



cm	 B	400	500	600	700	800	900	1000
 A		€						
250		5.943	6.414	6.885	7.356	7.981	8.452	8.923
300		6.238	6.782	7.325	7.868	8.565	9.108	9.651
350		6.535	7.150	7.765	8.380	9.148	9.763	10.378
400		6.830	7.517	8.204	8.890	9.732	10.419	11.106
450		7.126	7.885	8.644	9.402	10.316	11.074	11.833
500		7.422	8.253	9.083	9.914	10.899	11.730	12.560

SOLTIS 92

cm	 B	400	500	600	700
 A		€			
250		6.073	6.577	7.081	7.584
300		6.395	6.977	7.559	8.142
350		6.717	7.377	8.038	8.699
400		7.038	7.778	8.517	9.256
450		7.361	8.178	8.995	9.813
500		7.682	8.578	9.474	10.371

Modalità di cucitura per i tessuti
Means of sewing fabrics
Art und Weise der Naht für Stoffe
Modalités de couture pour les tissus
Tipo de costura para el tejido

DACRON LAMINATO

cm	 B	400	500	600	700	800	900	1000
 A		€						
250		6.630	7.272	7.915	8.558	9.355	9.998	10.640
300		7.063	7.812	8.561	9.311	10.214	10.963	11.712
350		7.497	8.352	9.207	10.063	11.072	11.927	12.783
400		7.929	8.891	9.852	10.814	11.930	12.892	13.854
450		8.363	9.431	10.498	11.566	12.789	13.857	14.925
500		8.796	9.970	11.145	12.319	13.647	14.821	15.995

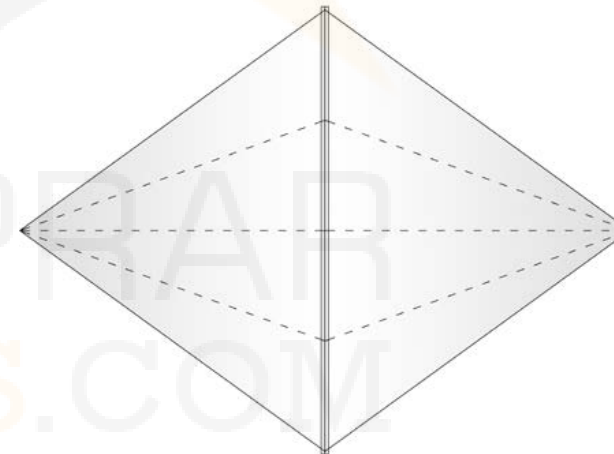

 Boma giuntato / Jointed boom / Gekoppelte Tuchwelle / Bome jointé / Eje unido

GENNIUS SAILS S4

VELAS MOTORIZADAS

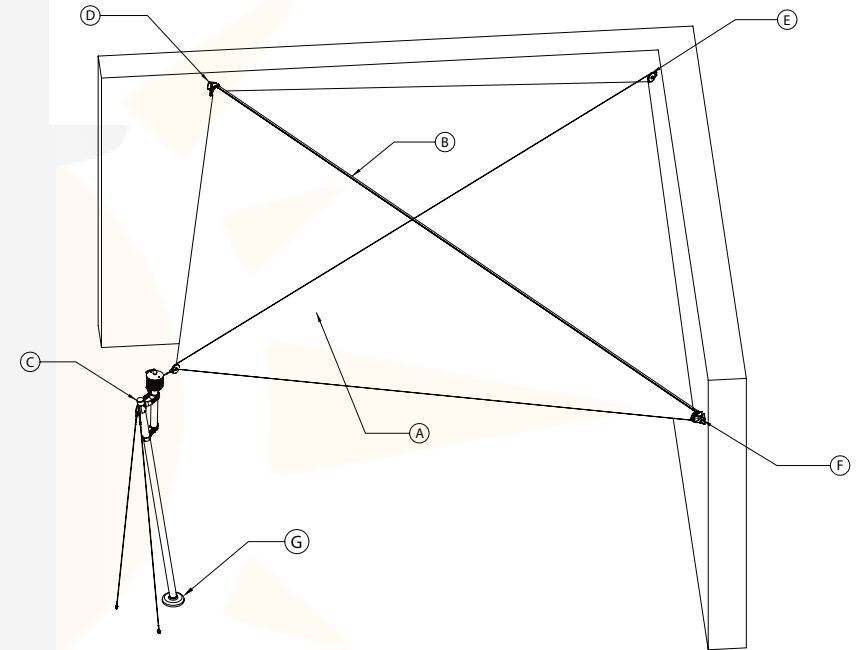
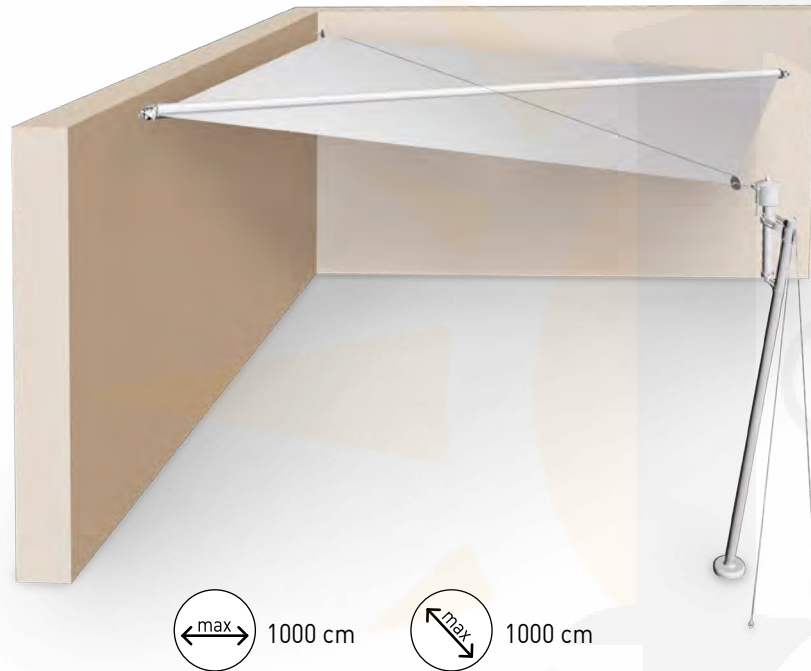

 Sistema ombreggiante motorizzato a vela completo di struttura con 1 albero portante, boma e rinvio ancorati a parete con staffe in 3 punti, tensionamento con funi in acciaio inox aisi 316, tessuto a scelta (Dacron laminato, Soltis 92, Star Light, Tempotest Star resinato) avvolto su boma centrale in alluminio anodizzato.

Resistenza al vento garantita fino alla classe 2 secondo la UNI EN 13561.

Struttura non adatta alla tenuta dell'acqua e al carico di neve.

La formazione di condensa sul telo non è da considerarsi difetto, si tratta di un fenomeno naturale.

* Possibilità boma invertito da C a E

 Motorized sun protection sail system, made of 1 bearing mast, boom and return device fixed on wall with bracket in 3 points, tightened by 316 stainless steel cables, preferred fabric (rolled Dacron, Soltis 92, Star Light, Tempotest Star) enroled on a central anodized aluminium boom. Guaranteed wind resistance up to class 2 according to UNI EN 13561.

Structure not suitable for holding water and snow loads.

The development of condensation on the fabric is natural and not to be considered as a defect.

* Inverted boom possibilities from C to E

 Motorisiertes Sonnensegelsystem, besteht aus 1 Tragstütze (Edelstahl 316), Tuchwelle mit 3 Wandbefestigungsstellen, Spannungssystem durch Edelstahlseilen AISI 316, Tücher nach Wahl erhältlich (Dacronlaminat, Soltis 92, Star Light, Tempotest Star), auf eine mittlere Tuchwelle aus eloxierten Aluminium gerollt.

Windbeständigkeit: Nach UNI EN 13561 bis Klasse 2 garantiert.

Zum Halten von Wasser und Schneelast nicht geeignete Struktur.

Die Entwicklung von Kondensation auf den Stoff ist nicht ein Defekt, sondern ist natürlich.

* Umdrehmöglichkeit der Wickelwelle von C nach E

 Système de voile d'ombrage motorisée, intégrant 1 mat portant avec 3 supports muraux avec supporte, tension par câble en acier Aisi 316, tissu au choix (Dacrom laminé, Soltis 92, Star Light, tempotest star) enroulé sur un bome central en aluminium anodisé.

Résistance au vent garantie jusqu'à la classe 2 selon la norme UNI 13561.

Structure non étanche à l'eau et non adaptée au poids de la neige.

Le développement de condensation sur le tissu n'est pas considéré un défaut, c'est un phénomène naturel.

* Possibilité boma inversée de C à E

 Sistema de protección solar motorizado a vela con estructura con 1 columna portante, eje y reenvio anclado a pared con soporte en 3 puntos, tensionamiento con cables de acero inox aisi 316, tejido a escoger (Dacron laminado, Soltis 92, Star Light, Tempotest Star resinado) enrollado sobre eje central de aluminio anodizado.

Resistencia al viento garantizada hasta la clase 2 según la UNI EN 13561.

Estructura inadecuada para soportar el agua y el peso de la nieve.

La formación de agua de condensación no es un defecto sino un fenómeno natural.

* Posibilidad de invertir el eje de la posición de C a E

- A Telo
- B Boma
- C Albero porta motore
- D Staffa porta boma con cricco
- E Staffa rinvio
- F Staffa porta boma folle
- G Copripiedino (optional)

- A Fabric
- B Boom
- C Drive shaft
- D Bracket boom with "ratchet"
- E Return bracket
- F Free boom bracket
- G foot coverlet (optional)

- A Tuch
- B Tuchwelle
- C Stütze mit Motor
- D Konsolen Trägerstütze mit Heber
- E Rückholkonsole
- F Konsolen Trägerstütze
- G Bodenbefestigungsdeckel (Optional)

- A Toile
- B Bome
- C Mat porte moteur
- D Supporte porte bome avec cric
- E Support renvoi
- F Supporte porte bome libre
- G Cache pied (optional)

- A Tela
- B Eje
- C Columna porta motor
- D Soporte porta eje cric
- E Soporte reenvio
- F Soporte porta eje loco
- G Cubrepies (opcional)



Schema tecnico generale/General technical plan/Allgemein - technisches Schema/Plan technique général/Dibujo tecnico general

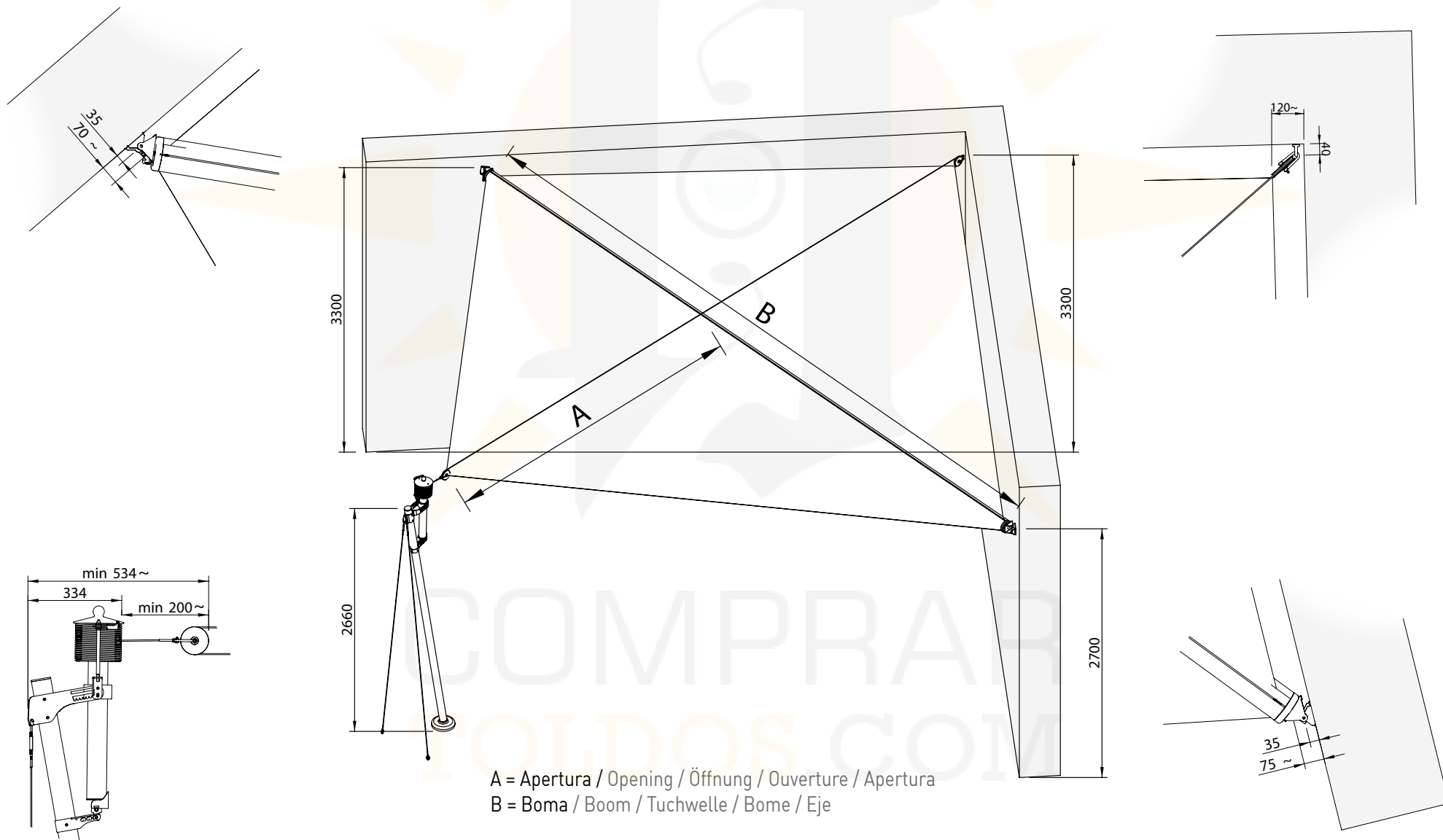

GENNIUS SAILS S4

 **A**
Apertura / Opening / Öffnung / Ouverture / Apertura



 **B**
Boma / Boom / Tuchwelle / Bome / Eje

Versione Inox / Inox version



TEMPOTEST STAR LIGHT

cm	 B	400	500	600	700	800	900	1000
 A		€						
250		4.542	4.816	5.089	5.363	5.636	5.910	6.183
300		4.761	5.089	5.417	5.745	6.073	6.401	6.729
350		4.980	5.363	5.745	6.128	6.511	6.893	7.276
400		5.198	5.636	6.073	6.511	6.948	7.386	7.823
450		5.417	5.910	6.401	6.893	7.386	7.878	8.370
500		5.636	6.183	6.729	7.276	7.823	8.370	8.917



TEMPOTEST STAR RESINATO

cm	 B	400	500	600	700	800	900	1000
 A		€						
250		5.543	6.015	6.485	6.956	7.581	8.053	8.524
300		5.840	6.382	6.925	7.468	8.165	8.708	9.251
350		6.135	6.750	7.365	7.980	8.748	9.363	9.978
400		6.431	7.118	7.805	8.492	9.332	10.019	10.706
450		6.726	7.486	8.245	9.003	9.916	10.674	11.433
500		7.022	7.853	8.684	9.515	10.499	11.330	12.161

SOLTIS 92

cm	 B	400	500	600	700
 A		€			
250		5.674	6.177	6.681	7.185
300		5.995	6.577	7.160	7.742
350		6.317	6.978	7.638	8.299
400		6.639	7.378	8.117	8.856
450		6.961	7.779	8.596	9.414
500		7.283	8.179	9.075	9.971

DACRON LAMINATO

cm	 B	400	500	600	700	800	900	1000
 A		€						
250		6.230	6.873	7.515	8.159	8.955	9.598	10.241
300		6.664	7.412	8.162	8.911	9.814	10.563	11.312
350		7.097	7.952	8.808	9.663	10.672	11.528	12.383
400		7.530	8.492	9.454	10.415	11.531	12.492	13.454
450		7.963	9.032	10.100	11.167	12.389	13.457	14.526
500		8.397	9.571	10.745	11.920	13.247	14.422	15.596

Modalità di cucitura per i tessuti
Means of sewing fabrics
Art und Weise der Naht für Stoffe
Modalités de couture pour les tissus
Tipo de costura para el tejido

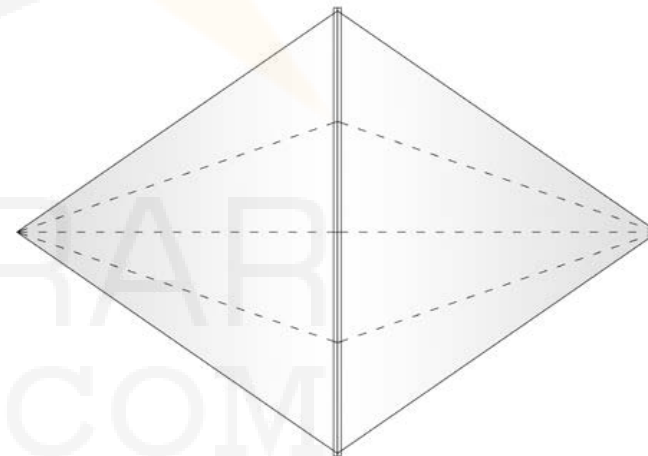

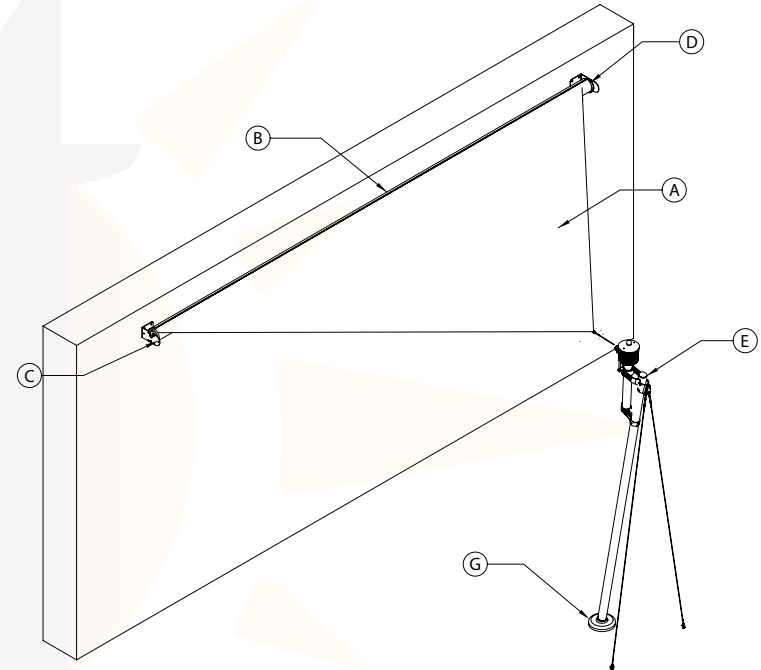

 Boma giuntato / Jointed boom / Gekoppelte Tuchwelle / Bome jointé / Eje unido



 Sistema ombreggiante motorizzato a vela completo di struttura con 1 albero portante e boma ancorato con 2 staffe a parete in acciaio inox 316, tensionamento con funi in acciaio inox aisi 316, tessuto a scelta (Dacron laminato, Soltis 92, Star Light, Tempotest Star resinato) avvolto su boma centrale in alluminio anodizzato. Resistenza al vento garantita fino alla classe 2 secondo la UNI EN 13561. Struttura non adatta alla tenuta dell'acqua e al carico di neve. La formazione di condensa sul telo non è da considerarsi difetto, si tratta di un fenomeno naturale. * Possibilità boma invertito da C a E

 Motorized sun protection sail system with structure made of 1 mast and boom fixed on wall in 2 points (316 stainless steel), tightened by 316 stainless steel cables, preferred fabric (rolled Dacron, Soltis 92, Star Light, Tempotest Star) enroled on a central anodized aluminium boom. Guaranteed wind resistance up to class 2 according to UNI EN 13561. Structure not suitable for holding water and snow loads. The development of condensation on the fabric is natural and not to be considered as a defect. * Inverted boom possibilities from C to E

 Motorisiertes Sonnensegelsystem, besteht aus 1 Tragstütze (Edelstahl 316), Tuchwelle mit 2 Wandbefestigungsstellen, Spannungssystem durch Edelstahlseilen AISI 316, Tücher nach Wahl erhältlich (Dacronlaminat, Soltis 92, Star Light, Tempotest Star), auf eine mittlere Tuchwelle aus eloxierten Aluminium gerollt. Windbeständigkeit: Nach UNI EN 13561 bis Klasse 2 garantiert. Zum Halten von Wasser und Schneelast nicht geeignete Struktur. Die Entwicklung von Kondensation auf den Stoff ist nicht ein Defekt, sondern ist natürlich. * Umdrehmöglichkeit der Wickelwelle von C nach E

 Système de voile d'ombrage motorisée, intégrant 1 mat portant avec 2 supports muraux (acier Inox 316), tension par câble en acier Aisi 316, tissus au choix (Dacrom laminé, Soltis 92, Star Light, tempotest star) enroulé sur un bome central en aluminium anodisé. Résistance au vent garantie jusqu'à la classe 2 selon la norme UNI 13561. Structure non étanche à l'eau et non adaptée au poids de la neige. Le développement de condensation sur le tissu n'est pas considéré un défaut, c'est un phénomène naturel. * Possibilité boma inversée de C à E

 Sistema de protección solar motorizado a vela con estructura con 1 columna portante y eje anclado en 2 partes a pared (acero inox 316), tensionamiento con cables de acero inox aisi 316, tejido a escoger (Dacron laminado, Soltis 92, Star Light, Tempotest Star resinado) enrollado sobre eje central de aluminio anodizado. Resistencia al viento garantizada hasta la clase 2 según la UNI EN 13561. Estructura inadecuada para soportar el agua y el peso de la nieve. La formación de agua de condensación no es un defecto sino un fenómeno natural. * Posibilidad de invertir el eje de la posición de C a E+

- A Telo
- B Boma
- C Staffa porta boma con cricco
- D Staffa porta boma folle
- E Albero porta motore
- G Copripiedino (optional)

- A Fabric
- B Boom
- C Bracket boom with "ratchet"
- D Free boom bracket
- E Drive shaft
- G foot coverlet (optional)

- A Tuch
- B Tuchwelle
- C Konsolen Trägerstütze mit Heber
- D Konsolen Trägerstütze
- E Stütze mit Motor
- G Bodenbefestigungsdeckel (Optional)

- A Toile
- B Bome
- C Supporte porte bome avec cric
- D Supporte porte bome libre
- E Mat porte moteur
- G Cache pied (optional)

- A Tela
- B Eje
- C Soporte porta eje cric
- D Soporte porta eje loco
- E Columna porta motor
- G Cubrepies (opcional)



Schema tecnico generale/General technical plan/Allgemein - technisches Schema/Plan technique général/Dibujo tecnico general

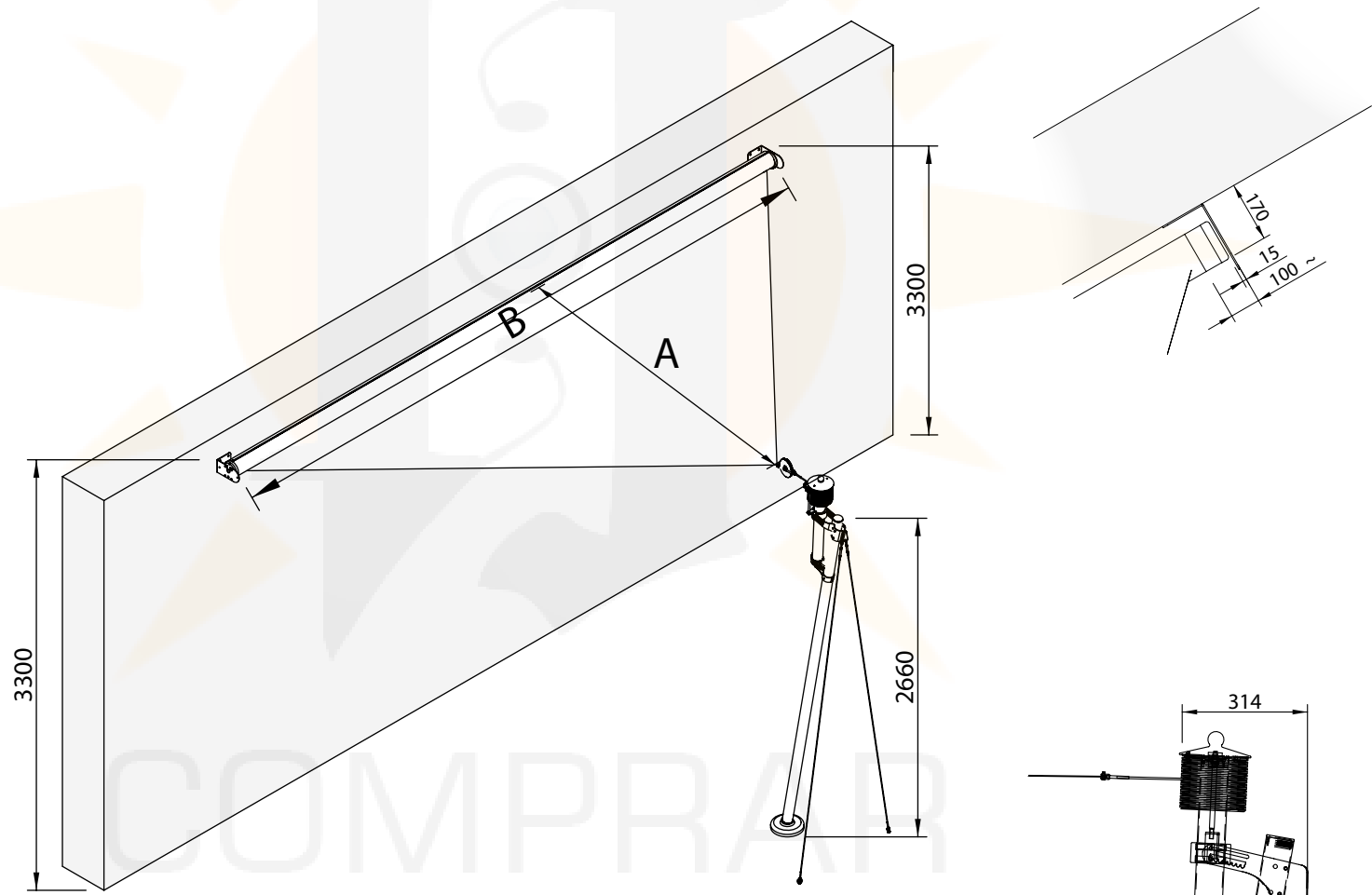

A = Apertura / Opening / Öffnung / Ouverture / Apertura
B = Boma / Boom / Tuchwelle / Bome / Eje

GENNIUS SAILS S5



Apertura / Opening / Öffnung / Ouverture / Apertura



Boma / Boom / Tuchwelle / Bome / Eje

Versione Inox / Inox version

TEMPOTEST STAR LIGHT

cm	☒ B	400	500	600	700	800	900	1000
☒ A		€						
250		4.364	4.647	4.929	5.212	5.649	5.932	6.214
300		4.509	4.826	5.143	5.461	5.931	6.248	6.566
350		4.654	5.005	5.356	5.709	6.214	6.566	6.917
400		4.799	5.184	5.571	5.957	6.497	6.882	7.268
450		4.944	5.365	5.785	6.205	6.779	7.199	7.619
500		5.090	5.544	5.998	6.452	7.061	7.516	7.971

TEMPOTEST STAR RESINATO

cm	☒ B	400	500	600	700	800	900	1000
☒ A		€						
250		4.398	4.688	4.980	5.271	5.716	6.007	6.298
300		4.549	4.877	5.203	5.531	6.012	6.339	6.667
350		4.701	5.064	5.428	5.790	6.308	6.671	7.034
400		4.853	5.252	5.651	6.051	6.604	7.002	7.402
450		5.005	5.440	5.876	6.310	6.899	7.334	7.770
500		5.157	5.628	6.099	6.570	7.195	7.667	8.137

SOLTIS 92

cm	☒ B	400	500	600	700
☒ A		€			
250		4.462	4.769	5.077	5.384
300		4.627	4.974	5.320	5.668
350		4.792	5.178	5.565	5.950
400		4.957	5.382	5.808	6.233
450		5.123	5.586	6.051	6.515
500		5.287	5.791	6.295	6.798

DACRON LAMINATO

cm	☒ B	400	500	600	700	800	900	1000
☒ A		€						
250		4.741	5.118	5.495	5.871	6.403	6.780	7.157
300		4.961	5.392	5.822	6.252	6.837	7.266	7.697
350		5.182	5.665	6.149	6.632	7.269	7.753	8.236
400		5.403	5.939	6.476	7.012	7.703	8.239	8.776
450		5.623	6.213	6.803	7.393	8.136	8.726	9.316
500		5.844	6.486	7.130	7.773	8.569	9.212	9.855

Modalità di cucitura per i tessuti
 Means of sewing fabrics
 Art und Weise der Naht für Stoffe
 Modalités de couture pour les tissus
 Tipo de costura para el tejido

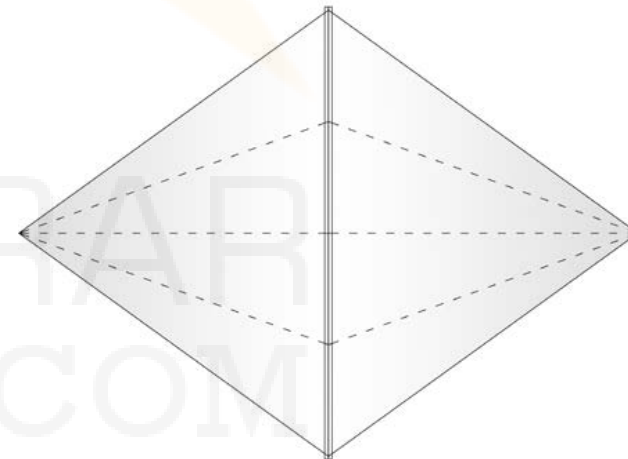

☒ Boma giuntato / Jointed boom / Gekoppelte Tuchwelle / Bome jointé / Eje unido

	€
Copripiedino dritto - straight cover foot - Gerader Bodenbefestigungsdeckel - Cache pied droit - Cubrepie derecho	(PZ) 97
Copripiedino inclinato - inclined cover foot - schräger Bodenbefestigungsdeckel - Cache pied incliné - Cubrepie inclinado	(PZ) 97
Radiocomando Telis Atrio 1 - Remote control Telis Atrio 1 - Télècommande Telis Atrio 1 - Fernbedienung Telis Atrio 1	(PZ) 90
Radiocomando Telis Atrio 4 - Remote control Telis Atrio 4 - Télècommande Telis Atrio 4 - Fernbedienung Telis Atrio 4	(PZ) 127
Sensore vento radio Eolis rts - Radio wind sensor Eolis rts - Windwächter Eolis rts - Capteur vent/radio Eolis rts - Sensor viento Eolis rts	(PZ) 227
Supporto Inox per sensore vento radio Eolis rts - Steel support for Wind sensor Radio Eolis RTS - Edelstahlhalterung für Windwächter Eolis rts - Support Inox pour senseur vent radio Eolis rts - Soporte inox para sensor viento Eolis rts	(PZ) 78
Faro per illuminazione con supporto a muro - light with wall support - Beleuchtung mit Wandkonsolenbefestigung - Phare d'éclairage avec support mural - Faro para iluminacion con soporte a pared	(PZ) 254
Faro per illuminazione con supporto ad albero - light with shaft support - Beleuchtung mit Stützenkonsolenbefestigung - Phare d'éclairage avec support sur mat - Faro para iluminacion con soporte a columna	(PZ) 350
Piastra zavorrabile per albero dritto* - Plate for straight shaft - beschwerende Platte für den geraden Baum - Support lestable pour mat droit - Placa lastrada para columna recta	(PZ) 961
Piastra zavorrabile per albero inclinato* - Plate for inclined shaft - beschwerende Platte für den geneigten Baum - Support lestable pour mat incliné - Placa lastrada para columna inclinada	(PZ) 1.331
*Solo per showroom ed esposizioni interne - *For showroom and internal exposures only - *Nur für den Showroom und interne Ausstellungen - *Uniquement pour showroom et expositions internes - *Sólo para sala de exposición y exposiciones interiores	
Per Gennius Sails con tessuto non triangolare o a rombo è necessario prevedere Kit motore aggiuntivo comprensivo di centralina: 1637 € - For Gennius Sails with no triangular fabric or with a rhomboidal shape fabric, use the added motor kit with control unit included: 1589 € - Für Gennius Sails mit nicht dreieckigem Stoff oder mit Rautenform ist es notwendig ein Kit mit einem zusätzliches Motorsteuergerät einzuplanen: 1589 € - Pour gennius Sails avec toile non triangulaire ou spéciale il est nécessaire de prévoir un Kit moteur supplémentaire comprenant centrale 1589 € - Para Gennius Sails con tejido no triangular o a rombo es necesario prever Kit motor adjunto incluyendo la centralita: 1589 €	
Accessori per installazione - Installation tools - Montagzubehör - Accessoire pour installation - Accesorios para instalación	
Cesoia per funi in acciaio - Shear for steel cables - Edelstahlseilschere - Pince coupante pour cable - Cizalla para cable de acero	(PZ) 472
Pressa idraulica manuale/fune - Hydraulic manual/rope press - Manuelle Hydraulikpresse/ hydraulische Seilpresse - Presse hydraulique manuelle/câble - Prensa hidráulica manual/cable	(PZ) 1.849
Pressa idraulica manuale/fune + cesoia per funi - Hydraulic manual/rope press + rope cutter - Manuelle Hydraulikpresse/ hydraulische Seilpresse + Schneideapparat für Seile - Presse hydraulique manuelle/câble + cisaille pour câbles - Prensa hidráulica manual/cable + cizalla para cables	(CF) 2.321