



COMPRAR  
TOLDOS.COM

[www.comprartoldos.com](http://www.comprartoldos.com)  
[info@comprartoldos.com](mailto:info@comprartoldos.com)

Brazo Stor



## Características y aplicaciones



Sistema con aplicación principal en balcones con techo, con brazos de 50 cm. montados en el tubo de carga y con fijación sobre la baranda del balcón mediante una pieza que permite dos tipos de sujeción:

- a) Toldo. (Inclinación).
- b) Telón. (Vertical).

## Characteristics and applications



System designed for use on covered balconies, with 50 cm arms assembled on the load bar and fixed to the balcony rail by means of an attachment which allows two different types of fastening:

- a) Awning. (Inclined).
- b) Blind. (Vertical).

## Caractéristiques et les usages



Système s'appliquant principalement sur des balcons avec toit, avec des bras de 50 cm montés sur le tube porteur et avec une fixation sur la balustrade du balcon au moyen d'une pièce qui permet deux types de serrage :

- a) Store. (Inclinaison).
- b) Toile. (Verticale).

## Eigenschaften und Anwendungen



System, das hauptsächlich für den Einsatz an Balkonen mit Dachvorsprung gedacht ist. Mit an der Fallstange 50 cm langen montierten Armen und zwei Befestigungen am Geländer des Balkons:

- a) Markise. (Neigung).
- b) Vorhang. (Vertikal).



# Brazo Stor

Despiece - Stor Arm parts - Pièces de Bras Stor - Komponenten der Arm Stor

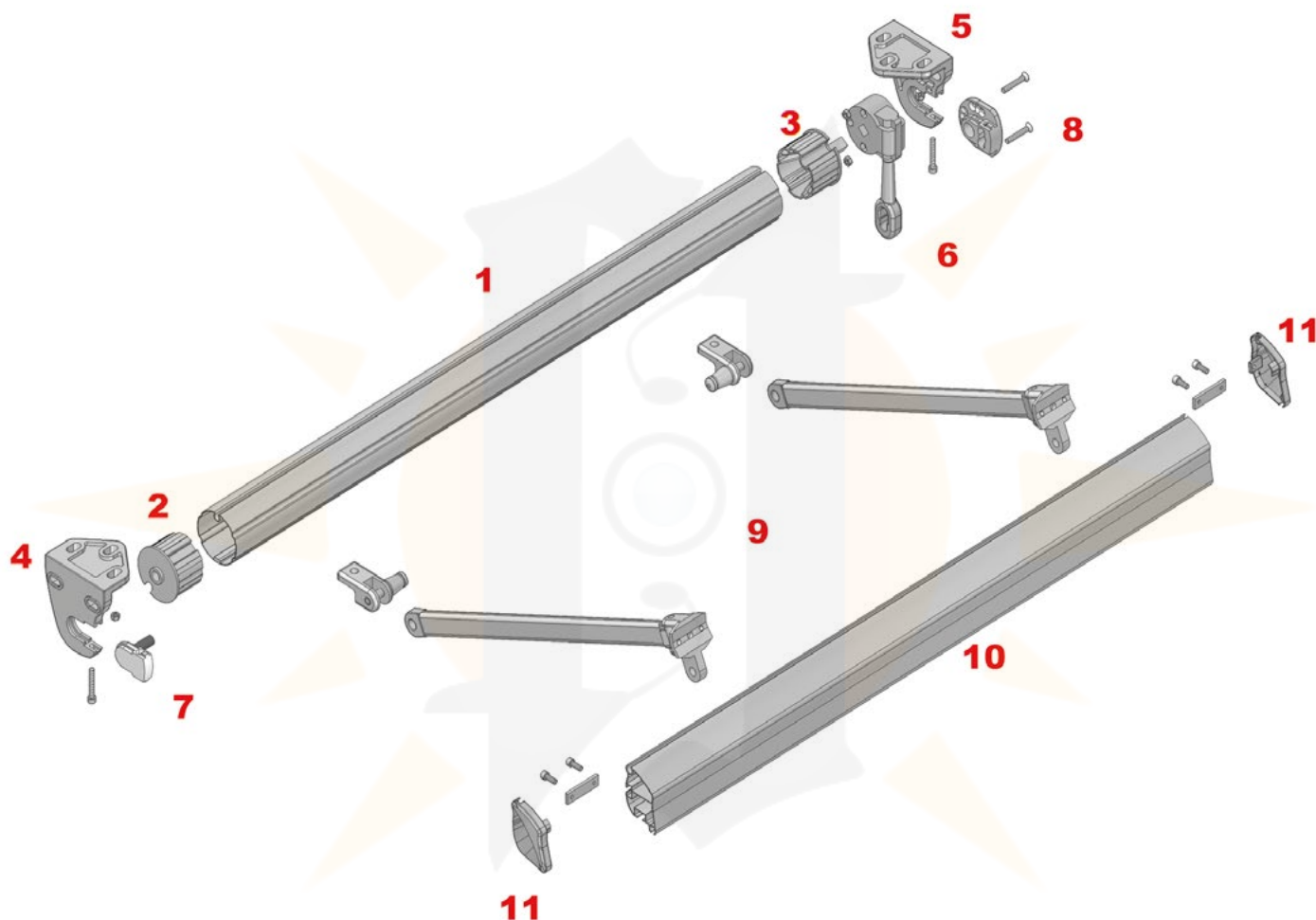

- 1: Tubo de enroll
- 2: Casquillo sin punta
- 3: Casquillo punta máquina
- 4: Soporte jaraba izquierdo
- 5: Soporte jaraba derecho
- 6: Máquina
- 7: Acople punta
- 8: Acople máquina
- 9: Juego brazos stor
- 10: Perfil carga cazorla
- 11: Tapones perfil de carga



- 1: Roller tube
- 2: Plug without tip
- 3: Gearbox plug
- 4: Left Jaraba support
- 5: Right Jaraba support
- 6: Gearbox
- 7: Point coupling
- 8: Gearbox coupling
- 9: Stor arms kit
- 10: Cazorla load profile
- 11: Load profile caps



- 1: Tube d'enroulement
- 2: Embout sans pointe
- 3: Embout côté opposé au treuil
- 4: Support Jaraba gauche
- 5: Support Jaraba droit
- 6: Treuil
- 7: Raccord côté opposé au treuil
- 8: Raccord treuil
- 9: Jeu bras stor
- 10: Barre de charge Cazorla
- 11: Caches barre de charge



- 1: Tuchwalze
- 2: Buchse ohne Stift
- 3: Buchsenstift/Getriebe
- 4: Linker Halter Jaraba
- 5: Rechter Halter Jaraba
- 6: Getriebe
- 7: Ankopplung Stift
- 8: Ankopplung Getriebe
- 9: Armsatz Stor
- 10: Fallstange Cazorla
- 11: Fallstangenabdeckung

Ref.: 510005\_\_

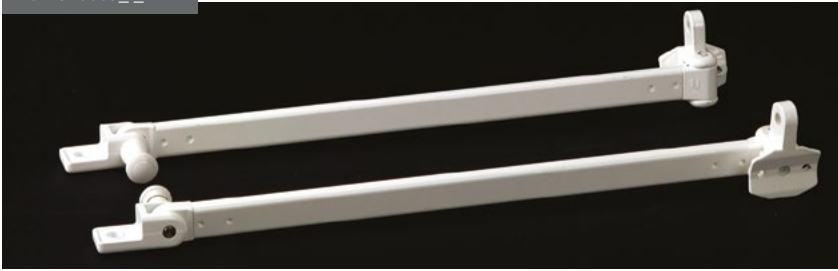

Juego Brazos Stor  
Stor arm kit  
Jeu de Bras Stor  
Armsatz Stor

Ref.: 510200\_\_



Juego Enganche Baranda  
Rail coupling kit  
Jeu Crochet Balustrade  
Befestigungsatz am Geländer

Ref.: 510400\_\_



Juego Herrajes Stor  
Stor brackets kit  
Jeu de Ferrures Stor  
Beschlagesatz Stor

Ref.: 510300\_\_



Terminal Inferior Stor  
Stor lower terminal  
Griffe Inférieure Stor  
Unteres Terminal Stor

Ref.: 510100\_\_



SopORTE Pared Stor  
Stor wall support  
Support Mur Stor  
Wandhalterung Stor

Ref.: 515060\_\_



Perfil Brazo Stor  
Stor arm profile  
Profilé Bras Stor  
Profil Arm Stor

Ref.: 500100\_\_



Juego Soportes Jaraba  
Jaraba supports kit  
Jeu de Supports Jaraba  
Set Jaraba-Halter

Ref.: 717000\_\_



Máquina Siplan 1.7  
1.7 Siplan gearbox  
Treuil Siplan 1.7  
Getriebe Siplan 1.7

Ref.: 500600\_\_



Juego Soportes Jaraba con Eje Doble  
Jaraba double axis support kit  
Jeu de Supports Jaraba avec Axe Double  
Set Jaraba-Halter mit Doppelachse

Ref.: 501500\_\_



SopORTE Jaraba de transmisión  
Jaraba transmission support  
Support Jaraba de transmission  
Übertragung Jaraba-Halter

# Brazo Stor

Datos Técnicos - Technical Data - Données Techniques - Technische Daten

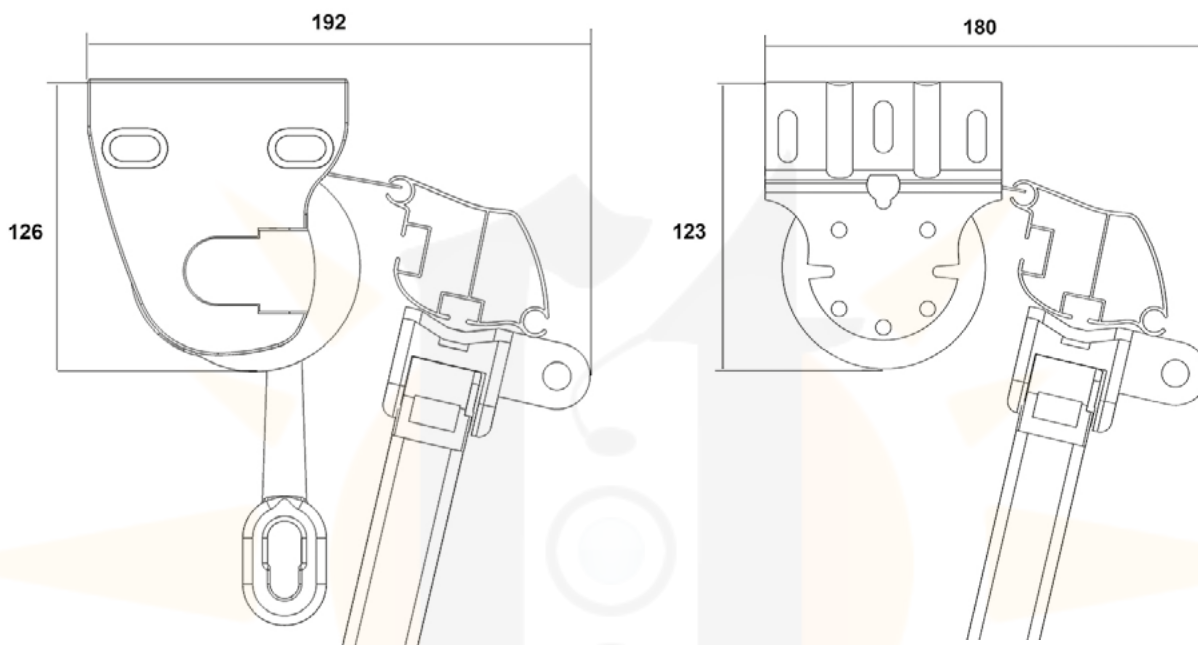

MEDIDAS DEL TUBO DE ENROLLE (no admite holguras) ROLLER TUBE MEASUREMENTS (no clearance) MESURES DU TUBE D'ENROULEMENT (il ne doit pas y avoir de jeu entre les pièces) MASSE DER TUCHWALZE (ohne Spiel)			
	MÁQUINA 1.7 MACHINE TREUIL GETRIEBE	MOTOR CON SOPORTE MOTOR WITH SUPPORT MOTEUR AVEC SUPPORT MOTORHALTER	MOTOR SIN SOPORTE MOTOR WITHOUT SUPPORT MOTEUR SANS SUPPORT MOTOR OHNE HALTER
SOPORTE CON EJE SUPPORT WITH AXIS SUPPORT AVEC AXE HALTER MIT ACHSE	LT-70 mm.	LT-60 mm.	LT-50 mm.
SOPORTE JARABA JARABA SUPPORT SUPPORT JARABA HALTER JARABA	LT-90 mm.	LT-80 mm.	LT-70 mm.

NOTA: LT= Línea total del toldo (tapas incluidas)

NOTE: LT = total line of the awning (caps dont)

REMARQUE: LT = Total largeur de le store (couvertles inclus)

NOTE: LT = Gesamtbreite (inkl. Abdeckungen)

COMPRAR  
TOLDOS.COM